

## **LED Runway Distance Remaining Sign**

### **Operation Manual**



Please read this manual carefully before construction, installation and operation of the product.

Please keep this manual properly for further reference.

This manual is subject to change without prior notice.

Airsafe Airport Equipment Co., Ltd.

## Revision Description

No.	Description	Version No.	Revised by	Approved by	Date
1	First release	V1.0			

## Table of Content

1.0 Forward .....	1
1.1 Illustrations and Meanings.....	1
1.2 Safety Rules and Notices.....	2
1.3 Quality Assurance and Responsibility .....	3
2.0 Introduction .....	4
2.1 Technical Specifications.....	4
2.3 Application Scope .....	5
2.4 Technical Parameters .....	5
2.5 Technical Features .....	5
2.7 Structure .....	7
3.0 Installation Overview .....	9
3.1 Installation Dimension and Installation Base Specification .....	9
3.2 Installation Steps .....	10
3.3 Wiring .....	11
3.4 Internal Electrical Configuration .....	14
3.5 Label Description .....	15
4.0 Introduction to Internal Circuit and Lamp.....	16
4.1 Lamp Driver .....	16
4.2 Input and Output Port of Driver .....	16
4.3 Wiring of LED Light Bar .....	17
4.4 Introduction to External Switch .....	19
5.0 Maintenance .....	21
5.1 Daily Maintenance.....	21
5.2 Replacement of LED Light Bar.....	22
5.3 Removal of Common Faults .....	22
5.4 Trouble Shooting.....	23
6.0 List of Components and Ordering of Spare Articles and Accessories .....	24
7.0 Packaging, Transportation and Storage .....	26
7.1 Packaging and Weight .....	26
7.2 Transportation Mode.....	26
7.3 Storage .....	26

## **1.0 Forward**

ICAO Airport Service Manual Part 9 “Airport Maintenance Practices” and FAA AC150/5345-26 Maintenance of Airport Visual Aid Facilities are the highest criteria for the field installation and maintenance of sign. This manual was compiled with considerable reference to these two criteria during preparation.

The content stated in this manual is absolutely important, so construction personnel must read it carefully before construction. After properly understanding the entire content of this manual, construction personnel should carry out the construction in strict accordance with the methods specified herein, to ensure that the product is safely and properly installed in place.

Routine airport maintenance personnel should carry out the routine maintenance in strict accordance with the methods specified by relevant provisions, to ensure that the lighting fixtures are in the best operation condition.

Related personnel must strictly follow safety criterion. Any personnel without specialized training is strictly forbidden to install and debug the sign. Live line work should be avoided under any circumstances. Construction or maintenance personnel should get acquainted with first-aid knowledge, in case of any unexpected events.

### **1.1 Illustrations and Meanings**

- Following illustrations will appear in this manual where necessary to remind or warn construction or maintenance personnel.
- Please continue reading the subsequent content of this manual after properly understanding the meanings of these illustrations.



- To remind that the behavior may cause serious injury or death.
- ※ Detailed description will be given in the box.



- To remind that the behavior may cause injury to people or damage to product.
- ※ Detailed description will be given in the box.



- To notify that the behavior is prohibited.
- ※ Detailed description will be given in the box.

## 1.2 Safety Rules and Notices



- Using the light fixtures outside of airport is strictly prohibited.
- ※ Insufficient maintenance or use may cause fault.



- During handling, the sign shall not drop onto the ground or collide.
- ※ Otherwise it may be damaged or cause personal injury.



- During installation, the power source shall be disconnected.
- ※ When the sign is installed, the current impact caused may cause damage to the lamp.



- Before getting the electricity, confirm whether the power source connected is M (202V) or S (6.6A).
- ※ It may cause internal electrical damage, or even fault of the power supply.



- Applying to great external force to the frangible mechanism at the lower part of the leg is strictly prohibited during installation.
- ※ Otherwise it may make the sign leg to be broken.



- Live maintenance of the sign or its maintenance when there is thunder or rain is strictly prohibited.
- ※ Otherwise it may cause electric shock or other accidents.



- Maintaining the electrical parts of the sign by the non-professional electricians is strictly prohibited.
- ※ Otherwise it may cause electric shock or other accidents.



- Touching the electrical equipment in the sign with wet hands is strictly prohibited.
- ※ Otherwise it may cause electric shock.



- The lead shall be immediately replaced when its sheath is damaged.
- ※ Otherwise it may cause electric shock.

### **1.3 Quality Assurance and Responsibility**

Any defect in design, material or workmanship, which may occur during proper and normal use over a period of one year from date of installation but less than 15 months from date of shipment, or within the warranty period of the tender, will be repaired or preplaced by manufacturer free of charge. The manufacturer doesn't bear the compensation resulting from improper maintenance method, mis-operation, and damages due to snow shoveling and weeding. Manufacturer's compensation is only limited to the sign itself, rather than user's other losses.

## 2.0 Introduction

This manual involves the following series signs:

LED RDRS -----LED Runway Distance Remaining Sign

Type of LED Taxiing Guidance Sign:

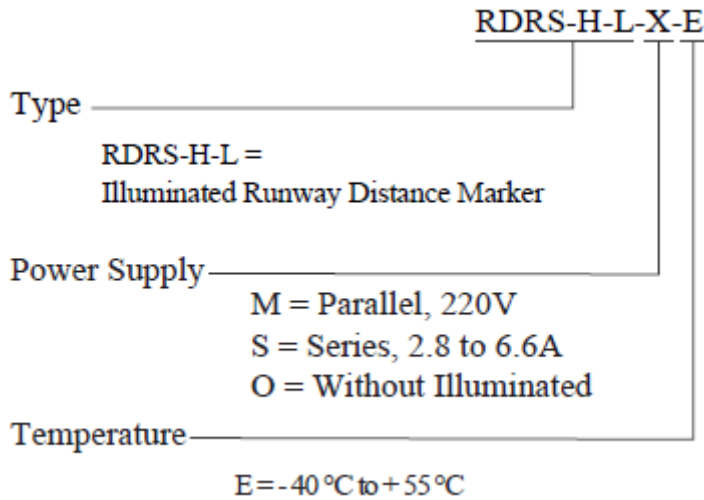

## 2.1 Technical Specifications

This product conforms to the provisions of the following standards or technical specifications. For dated standards or technical specifications, only the edition cited applies. For undated references, the latest edition of the referenced document (including any amendments) applies.

- Convention on International Civil Aviation Annex 14- *Aerodromes* Volume 1;
- International Civil Aviation Organization (ICAO)- *Aerodrome Design Manual*- Part 6: Frangibility;
- Federal Aviation Administration (FAA)AC 150/5345-44;
- NATO: STANAG 3316

## 2.2 Application Environment

- Altitude: below 4,000m;
- Relative air humidity: not more than 95%;
- Ambient temperature: -40°C ~ +55°C;
- In rain, snow, ice and water;
- Expose to corrosive salt atmosphere.
- Basic earthquake intensity VII.

## 2.3 Application Scope

Illuminated runway distance markers indicate the distance to the end of the active runway to the pilot.

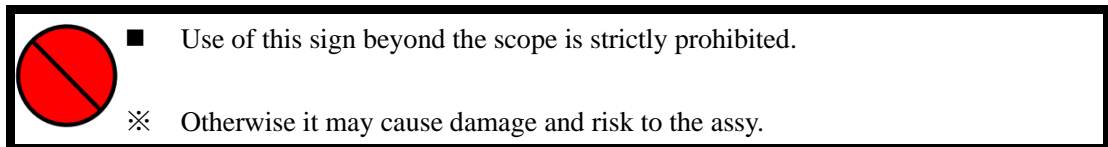

## 2.4 Technical Parameters

Main technical indexes of the product are as follows:

Lamp: LED light bar

Average life of lamp: 50,000h

Average brightness of panel:

White  $\geq 300$  cd/m<sup>2</sup>

The chroma complies with the provisions of 3.4 in Appendix 1 of IACO.

## 2.5 Technical Features

- Character settings, luminance, uniformity and chroma on the sign comply with the



requirements of Attachment 14 of ICAO;

- Long life, energy saving, maintenance free and other characteristics of LED will bring huge economic benefits to customers;
- International top brand LED and patented driving circuit greatly enhance the reliability and life of the sign;
- Strict LED color management ensures the consistency of light color;
- Internal reflected illumination method, more uniform lighting on the sign surface, without shadow;
- Panel is made of 4.5mm polycarbonate material containing the UV layer, which resists UV, impact and surface wear;
- Aluminum alloy section frame structure, strut passing through the case, firm and durable and high windproof capacity;
- Multiple waterproof structure design and high protection rating;
- The sign driving circuit has the modularized design for maintenance;
- Integrated surge protection function of the driving circuit and overheat protection module increase the reliability;
- The power factor is  $\geq 0.9$ ;
- EMI complies with the requirements of FAA and passes the inspection of the standard FCC Part15 Class A;
- Post air support of the front door frame makes the front door to be easily opened upward for daily cleaning and maintenance;
- Sign is made of the aluminum material, whose surface has preservative treatment. All fasteners are stainless steel products, which are applicable to various harsh environments.

## 2.6 Function Type

Type - White lettering on the Black background

## 2.7 Structure

### 2.7.1 Sketch of boundary dimension of sign

The signal width and height is both 1260mm, letters height is 1000mm.

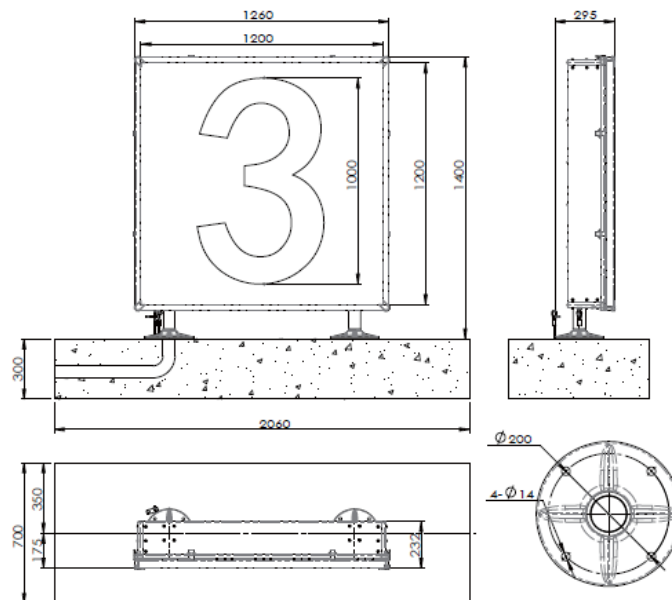

## 2.7.2 Sign structure and parts

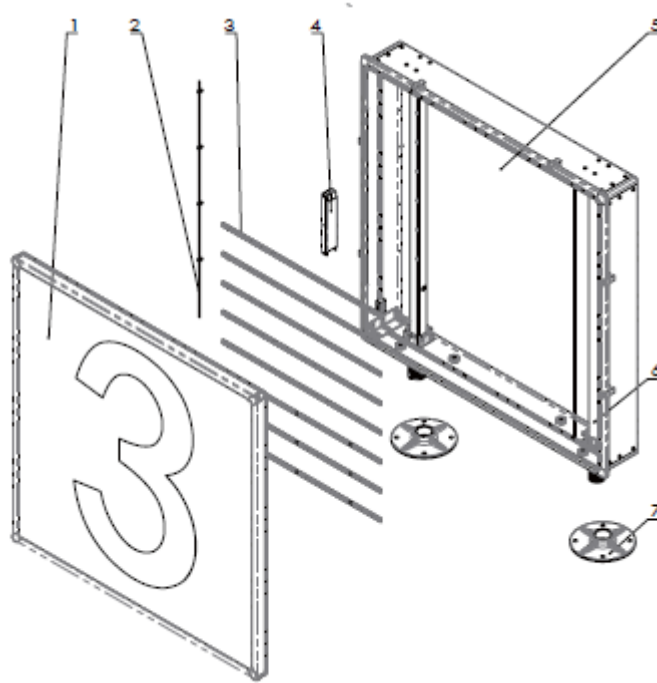

- |                      |                    |                  |                 |
|----------------------|--------------------|------------------|-----------------|
| 1. Front frame assy. | 2. Connecting line | 3. LED light bar | 4. Driver assy. |
| 5. Rear frame        | 6. Pole            | 7. Flange        |                 |

For wiring and daily maintenance, unfasten the surrounding hasps, rotate the front frame assembly forward and remove it to open the case for general operation.

### 3.0 Installation Overview

Correct installation is crucial for ensuring the normal operation of the sign and giving its full play. Make sure that the professional installs the sign.



- Installing the sign by the laypeople is strictly prohibited.
- ※ Otherwise, it may impact the normal use of the sign or cause major fault.

### 3.1 Installation Dimension and Installation Base Specification

The sign is often installed on the prefabricated cement foundation with M10×110 expansion screws.

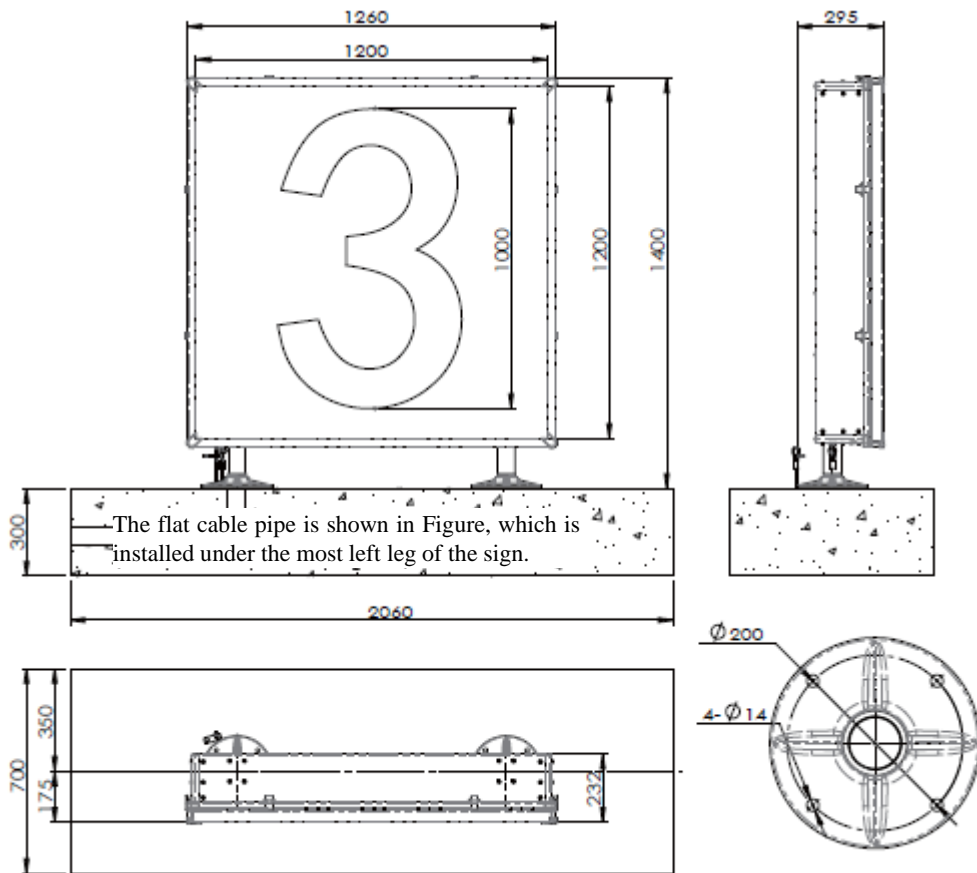



- The sign flange must be reliable and firmly locked.
- ※ In case of locking failed, the sign may be blown away by the air injection of the aircraft to cause accidents.



- The cement foundation dimension is only for reference. Please perform the construction by referring to the design.
- ※ Factors such as climate and soil texture of all airports impact the foundation dimension.

### 3.2 Installation Steps

The installation and fixation steps of the sign are as follows:

- Clean the site, especially the ground contacting the flange shall be flat;
- Unpack the sign packaging, check its appearance and confirm that it is not damaged;
- Place the sign onto the target cement foundation and confirm that its installation position is correct;
- Fix the sign onto the cement foundation with M10 expansion screws;
- The free end of the tether chain is fixed onto the flange screw;

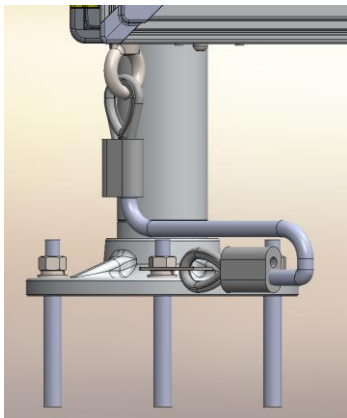

- The tether must be fixed with the flange screw, when the sign is installed.
- ※ Prevent to cause other potential safety hazards after the sign is broken.

- Check four screws in the peripheral direction of the flange and confirm that they are closely locked;



- Making sure that all screws on the flange are firmly locked when the sign is installed.
- ※ The sign is hit by the gas injection from the aircraft tail and typhoon throughout the year.

### 3.3 Wiring

The default wiring method of the power line of the sign is wiring in the extension pole (3.3.1).

Or the external flexible pipe wiring method of the sign may be employed according to the customer's requirements (3.3.2).

The internal electrical parts of the sign consist of the wire holder, driver, lamp leg and LED light bar. After the sign is installed and fixed, connect the power lead into the fixed hole on the corresponding wire holder according to the power indicated on the label nearby the wire holder. If there are several isolation transformer inputs on site or the customer requires several inputs, the power input of the line bank shall be increased accordingly.

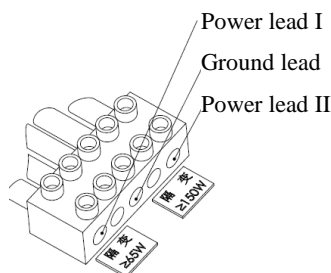



- Connect the power line in strict accordance with the label instruction.
- ※ Otherwise it may cause abnormal work of the circuit or failure of LED lighting up.

### 3.3.1 Wiring in extension pole

When the wiring in the extension pole is employed, the wiring steel tube must be laid in the cement foundation in advance. The user shall determine the cable ( $4\text{mm}^2$ ) length according to the actual requirements. One end of the cable is connected to the wire holder in the sign, which is connected with the power input terminal and ground terminal respectively and the other end is connected with the isolation transformer input terminal through A6 plug and the ground lead is connected to the ground pile head in the isolation transformer.

During wiring, please note that the earth terminal on the terminal block in the sign must be reliably grounded.

Wiring method I: Diagram of wiring in the extension pole

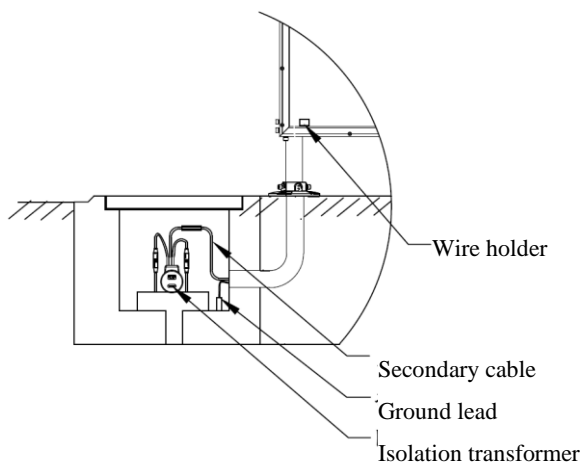

	■ Making sure good grounding of the ground lead.
	※ Otherwise, it may cause damage to the internal electrical parts, or even fault of power supply.

When it is powered on for the first time, please confirm the specification of the power source. Make sure that the specification of the power source used complies with the requirements and the matching parameters of the relevant parts comply with

the requirements of this specification.



- When it is powered on for the first time, please confirm the specification of the power source.
- ※ Otherwise, it may cause damage to the internal electrical parts, or even fault of power supply.

### 3.3.2 External flexible metal tubing wiring

The external flexible metal wiring method makes the construction more flexible and it is conveniently to connect the power lead to the power source pipeline nearby the sign and the flexible metal tubing effectively protects the power line.

One end of the cable is connected to the wire holder in the sign, which is connected with the power input terminal and ground terminal respectively and the other end is connected with the isolation transformer through A6 plug and the ground lead is grounded.

During wiring, please note that the earth terminal on the terminal block in the sign must be reliably grounded.

Wiring method II: Diagram of external flexible metal tubing wiring

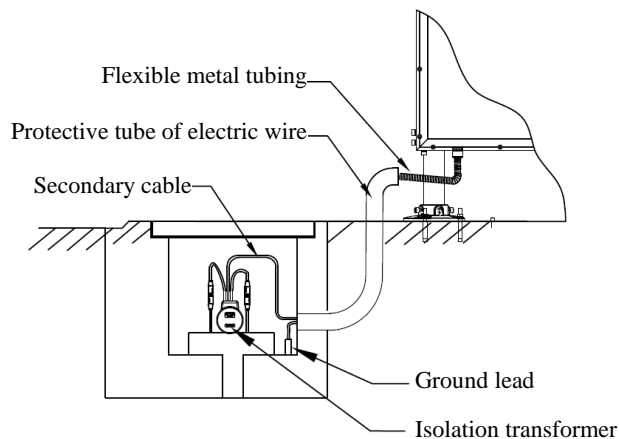



The incoming cable is threaded into the PVC protective tube after protected by the flexible tube. The foaming agent is used to block the PVC tube port to prevent external rain from entering the protective pipeline.

When it is powered on for the first time, please confirm the specification of the power source. Make sure that the specification of the power source used complies with the requirements and the matching parameters of the relevant parts comply with the requirements of this specification.

	<ul style="list-style-type: none"> <li>■ Must check whether the contact is good and has good waterproof performance.</li> <li>※ Otherwise, it may cause circuit fault.</li> </ul>
---	---

	<ul style="list-style-type: none"> <li>■ When it is powered on for the first time, please confirm the specification of the power source.</li> <li>※ Otherwise, it may cause damage to the internal electrical parts, or even fault of power supply.</li> </ul>
---	--

### 3.4 Internal Electrical Configuration

Visible Length (mm)	1200 x 1200
Qty of LED light bar	8
Qty of driver	1
Power (VA)	80
Isolation transformer (watts)	100

	<ul style="list-style-type: none"> <li>■ Overload use of the isolation transformer or driver is strictly prohibited.</li> <li>※ Otherwise, it may cause circuit fault or isolation transformer fault.</li> </ul>
---	--

	<ul style="list-style-type: none"> <li>■ Drivers must be used in series when two or more drivers are used.</li> <li>※ The parallel connection may cause failure of LED light bar lighting up or insufficient luminance.</li> </ul>
---	--

### 3.5 Label Description

A label is posted on the right of the sign, with the sample as follows:

<b>LED TGSL</b>			
Model		BP (L)Y3SHDII	
No.	O1	Lamp	LED 6W*6
Visible light length	1,000mm	Power source	2.8A-6.6A
Driver number	1	Isolation transformer	100W
Date of production	December 12, 2015	Factory No.	AS20151212001
<i><b>Airsafe</b></i>			

The label contains the following information:

Name, mark No. (sign position No.), sign length, driver number, date of production, signal panel character information, sign model, lamp type and number, input power, specification of isolation transformer and factory No.

## 4.0 Introduction to Internal Circuit and Lamp

### 4.1 Lamp Driver

M sign is applicable to constant voltage driving of 220V power supply.

The constant voltage driving in the sign is input by 220V AC power supply, with 180~300V wide voltage input and overvoltage and high temperature protection. The driver input is connected to the LED light bar with the special LED connecting cable. Take 100W as an example, a driver may drive 12 light bars, which may be configured randomly.

S sign is applicable to constant current driving of 2.8~6.6A power supply.

The high performance constant driving circuit in the sign is powered up by CCR, which is input into the driver through the isolation transformer, with the input current of 2.8A-6.6A. The driver output is connected to the LED light bar with the special LED connecting cable and a driver may drive 3-10 light bars, which may be configured randomly.

### 4.2 Input and Output Port of Driver

For the drive of M sign, the input power source specification, output wiring method and relevant requirements are indicated on the driver, as shown below:



For the drive of S sign, the input power source specification, output wiring method and relevant requirements are indicated on the driver, as shown below:

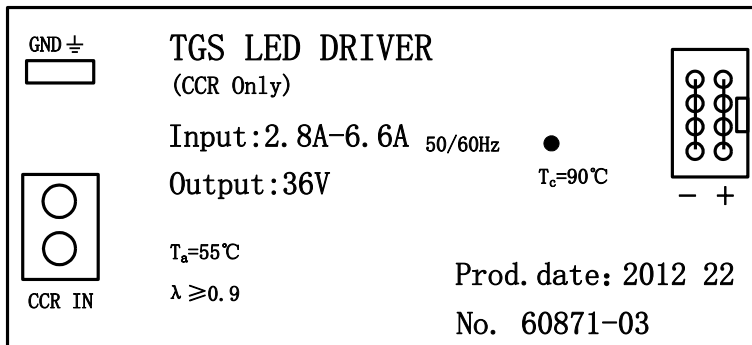

### 4.3 Wiring of LED Light Bar

The driver in the sign is configured according to the number of LED light bars. One driver may drive maximum 10 LED light bars and two drivers in series may drive maximum 10 LED light bars. The rest can be done in the same manner. The drivers may be continuously added only if their power does not exceed that of the isolation transformer.

The sign is not long. When only one driver is required, the input and output wiring is shown in Figure below. During installation, please check the transformer capacity to avoid CCR circuit oscillation due to overload:

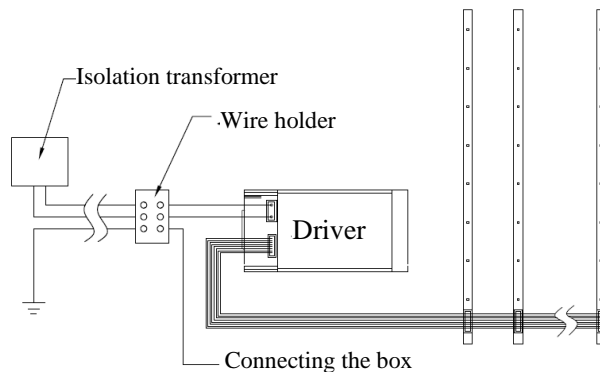

When the sign is long and several drivers are required, the input and output wiring is shown in Figure below. During installation, please check the transformer capacity to avoid CCR circuit oscillation due to overload:

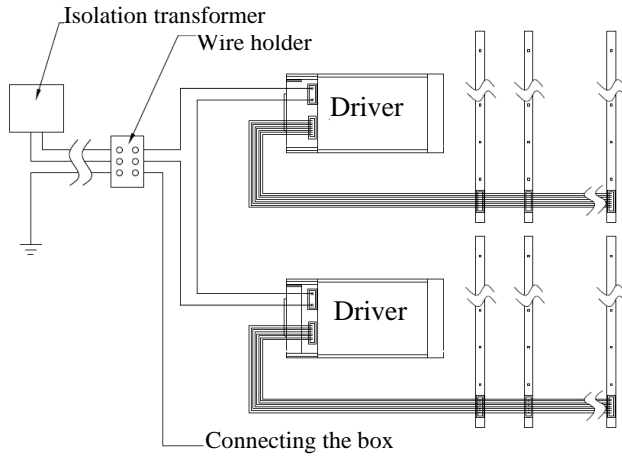



- Constant current CCR power supply is specifically used for the sign driver and using other power supplies are prohibited.
- ※ Otherwise, it may make LED failed, or even burn out the LED light bar and drive.

220V input wiring diagram is shown in Figure below:

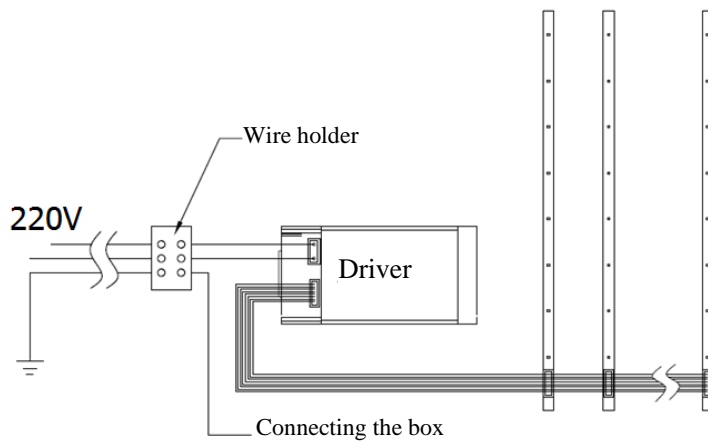

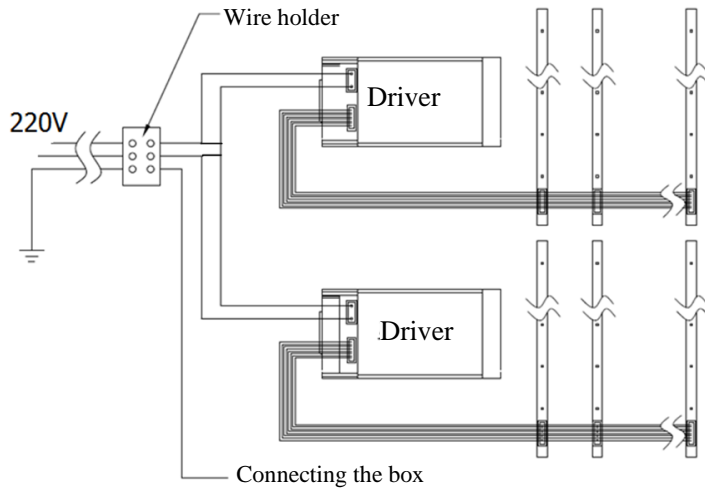

#### 4.4 Introduction to External Switch

The external switch may be installed for the sign according to the design requirements for ensuring safe maintenance, which disconnects the power supply for the sign and makes the secondary circuit of the isolation transformer short circuit.

The schematic diagram of wiring is shown below:

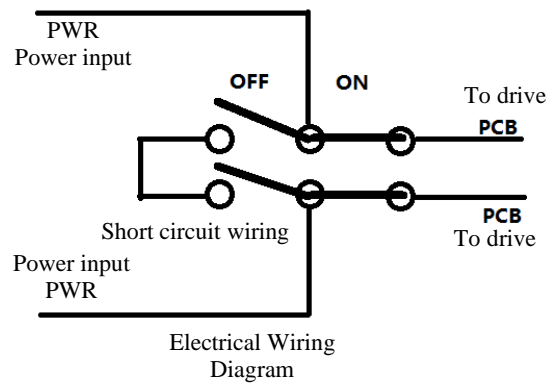

The schematic diagram of installation is shown below:

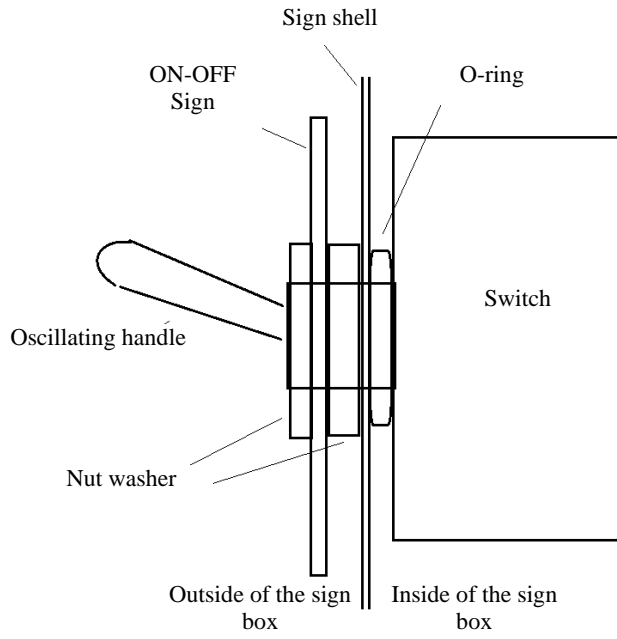

## 5.0 Maintenance

Daily maintenance suggestions supplied in this section are only for reference. The airport may refer to other provisions or maintenance experience of its workers to make its own daily maintenance criterion. The manufacturer does not specify it.

For maintenance of the airport lighting fixtures, please refer to 1.0 Preface. Maintenance is performed by the professional.

### 5.1 Daily Maintenance

Interval	Check	Activity
Every day	Frangible pole	Check whether the frangible pole is normal.
	Hasp	Confirm that it is buckled.
Every week	Cleaning	Clean the outside of the sign panel.
Every two months	Four hexagon bolts in the peripheral direction of the bottom flange	Check whether the screw is locked.



- Cleaning the transmitting film of the internal surface with sharp article or chemical corrosive item is strictly prohibited.
- ※ Otherwise it may damage the transmitting film of the internal surface.



- Making sure that each lock hasp is locked in place after maintenance.
- ※ The sign is hit by the gas injection from the aircraft tail and typhoon throughout the year.



- Making sure to carefully check whether the frangible part of the frangible pole is damaged.
- ※ Otherwise it cannot bear the hit by the gas injection from the aircraft tail and typhoon.



- Making sure to carefully check whether the screws of the frangible pole and flange are reliable.
- ※ Reliable frangible pole and flange makes safe operation of the airport.



## 5.2 Replacement of LED Light Bar

1. Loosen the hasps of three sides of the sign, open the front frame assy and remove it.
2. Take out the terminal block from the light bar and unscrew the fixed screw with a cross screwdriver.
3. Take out the old light bar and install a new one.
4. Assemble the front frame assy and buckle the hasps.

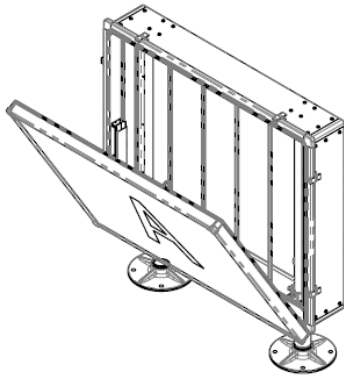

## 5.3 Removal of Common Faults

SN	Fault Phenomenon	Countermeasures
1	Non-uniform sign luminance	Clean the panel; Check and replace the LED light bar whose luminance is non-uniform;
2	Not lighting up of LED light bar	Check the power lead; Check the connection between the LED light bar and lamp leg; Lamp leg and driver wiring; Replace a new LED light bar; Replace the driver.



- The sign driver shall be purchased from the original manufacturer.
- ※ Otherwise it may cause abnormal LED work, or even burn out the LED light bar.



- The sign LED light bar must be purchased from the original manufacturer.
- ※ Otherwise it may cause abnormal LED work, or even burn out the LED light bar.

## 5.4 Trouble Shooting

SN	Failure	How to do
1	Nonuniform brightness	Clean the panel; Check and replace the LED strip
2	LED Strip doesn't work	Check wiring; Check connection of LED strip Check wiring of driver Replace the LED strip Replace the driver

## 6.0 List of Components and Ordering of Spare Articles and Accessories

The table in this chapter lists the components, spare articles and accessories of this product and relevant ordering information. Spare articles and accessories of this product needs to be ordered additionally, and the manufacturer accepts the order in assembly mode and separate order of components. When ordering, please contact the manufacturer or any distributor according to order number listed in the table.

The manufacturer suggests that some important components should be purchased from original factory to ensure various indicators of the lighting fixtures.

List of components and spare articles:

Structure No.	Component Name	Order No.	Description
1	Front frame assy	94664X	Front frame+ PC board The character information and sign size shall be provided. X=2 400-letter high
2	Drive assy	60871	Specific for LED of the taxiing guidance sign drive
3	LED light bar	960A02	LED light bar (H400)
4	Rear frame	94665X	Rear frame X=2 400-letter high
5	Extension pole	60845-I 60845-II 60845-III	I leg II leg III leg
6	Flange	27691	Flange 240

List of supporting accessories of this product is as follows:

Structure No.	Part Name	Order No.
2	Connecting line	71804
3	LED light bar (H400)	960A02
4	LED driver	60871
6	Pole (1380)	60846
7	Flange 240	27691

\* When ordering, provide the character information on the sign surface;

\* Ordering of the rear frame is unacceptable;

\* The power lead is the leg lead and the external flexible metal tubing wiring method shall be specifically indicated;

\* The manufacturer's default wind resistance is 240Km/h. If 322Km/h is required, it shall be specifically indicated;

\* If the customer has other special requirements, they shall be described in writing in detail.

	<ul style="list-style-type: none"> <li>■ If the sign drive is damaged, order it from us.</li> <li>※ Drive of other brands may cause lamp damage and use fault.</li> </ul>
---	---

	<ul style="list-style-type: none"> <li>■ If LED light bar is damaged, order it from us.</li> <li>※ Light bar of other brands may cause use fault of the sign.</li> </ul>
---	--

## **7.0 Packaging, Transportation and Storage**

### **7.1 Packaging and Weight**

Packaging: Packaging methods are different according to different sign sizes

Weight: Weight is different according to different sign sizes

Volume: Packaging volume is different according to different sign sizes

### **7.2 Transportation Mode**

Well packed products may be transported in three modes- railway, highway and air according to factors such as transportation distance, quantity of lights and delivery cycle.

### **7.3 Storage**

This product shall be stored in a place which is dry, well ventilated and far away from heat source and has no caustic gas. Custody should be checked on a regular basis.

The final right to interpret this manual is reserved by Airsafe Airport Equipment Co., Ltd.

Thanks for your purchasing and using AIRSAFE product!

Address: No.205, Changchuan Road, Baoshan  
District, Shanghai, China  
Postal Code: 200949  
Tel.: 021-6364 3114  
E-mail: sales@airsafe.com.cn