

12 Inches In-pavement Runway Lighting Fixtures

**In-pavement Approach Centerline Light and Cross Bar Light, In-pavement Approach Side-row Light, In-pavement Runway Threshold/ End Light, In-pavement Runway Threshold Light, In-pavement Runway Threshold Wing Bar Light, In-pavement Runway End Light and In-pavement Runway Edge Light
APP-12, APS-12, TAE-12,
THR-12, THW-12, END-12 and REL-12**

Operation Manual



Please read this manual carefully before construction, installation and operation of the product.

Please keep this manual properly for further reference.

This manual is subject to change without prior notice.

Airsafe Airport Equipment Co., Ltd.

Revision Description

| No. | Description | Version No. | Revised by | Approved by | Date |
|-----|-------------------------------------|-------------|---------------|-------------|---------------|
| 1 | First release | V1.0 | C.SY | W.GL | Aug. 01, 2006 |
| 2 | Type and composing adjustment added | V1.1 | Z.H | C.SY | Jul. 01, 2016 |

Table of Content

| | |
|---|----|
| 1.0 Foreword..... | 1 |
| 1.1 Illustrations and Meanings | 1 |
| 1.2 Safety Rules and Notices | 2 |
| 1.3 Quality Assurance and Responsibility | 3 |
| 2.0 Introduction..... | 4 |
| 2.1 Technical Specifications | 8 |
| 2.2 Application Environment | 8 |
| 2.3 Application Scope..... | 8 |
| 2.4 Technical Parameters | 9 |
| 2.5 Technical Features | 10 |
| 2.6 Structure..... | 11 |
| 3.0 Installation | 12 |
| 3.1 Installation Methods | 12 |
| 3.2 Identification of Different Types of Lighting Fixtures | 13 |
| 3.3 Installation Tools | 13 |
| 3.4 Screw and Torsion | 14 |
| 3.5 Relevant Configuration of Lighting Fixtures..... | 14 |
| 3.6 Installation..... | 15 |
| 4.0 Operation and Control..... | 17 |
| 4.1 Light Wiring Schematic Diagram..... | 17 |
| 4.2 Light Intensity Adjustment and Control | 18 |
| 5.0 Replacement of Components of Lighting Fixtures | 19 |
| 5.1 How to Dismount the Lighting Fixtures from Base | 20 |
| 5.2 How to Open Light Body..... | 20 |
| 5.3 How to Replace Lamp | 21 |
| 5.4 How to Replace Filter | 22 |
| 5.5 12 Inches Mounting Plate and Replacement Instructions..... | 23 |
| 5.6 How to Replace Prism and its Gasket Sleeve | 25 |
| 5.7 How to Replace Gasket..... | 26 |
| 5.8 Airtight Test of Lighting Fixtures..... | 27 |
| 6.0 Maintenance of Lighting Fixtures | 28 |
| 6.1 Daily Maintenance..... | 28 |
| 6.2 Regular Spot Check and Troubleshooting | 29 |
| 7.0 List of Components and Ordering of Spare Parts and Accessories..... | 30 |
| 8.0 Packaging, Transportation and Storage | 32 |
| 8.1 Packaging and Weight | 32 |
| 8.2 Transportation Mode..... | 32 |
| 8.3 Storage | 32 |

1.0 Foreword

ICAO *Airport Service Manual* Part 9 “Airport Maintenance Practices” and FAA AC150/5345-26 *Maintenance of Airport Visual Aid Facilities* are the highest criteria for site installation and maintenance of such lighting fixtures. This manual was compiled with considerable reference to these two criteria.

The content stated in this manual is absolutely important, so construction personnel must read it carefully before construction. After properly understanding the entire content of this manual, construction personnel should carry out the construction in strict accordance with the methods specified herein, to ensure that the product is safely and properly installed in place.

Routine airport maintenance personnel should carry out the routine maintenance in strict accordance with the methods specified by relevant provisions, to ensure that the lighting fixtures are in the best operation condition.

Related personnel must strictly follow safety criteria. Any personnel without specialized training is strictly forbidden to touch the lighting fixtures and devices. Live line work should be avoided under any circumstances. Construction or maintenance personnel should get acquainted with first-aid knowledge, in case of any unexpected events.

1.1 Illustrations and Meanings

- Following illustrations will appear in this manual where necessary to remind or warn construction or maintenance personnel.
- Please continue reading the subsequent content of this manual after properly understanding the meanings of these illustrations.



- To remind that the behavior may cause serious injury or death.
- ※ Detailed description will be given in the box.



- To remind that the behavior may cause injury to people or damage to product.
- ※ Detailed description will be given in the box.



- To notify that the behavior is prohibited.
- ※ Detailed description will be given in the box.

1.2 Safety Rules and Notices



- Using the light fixtures outside of airport is strictly prohibited.
- ※ Inadequate maintenance or casual touch will cause light faults.



- Making sure that CCR is on power-off state before the installation or maintenance of the lighting fixtures.
- ※ Current surge produced during the installation of the lighting fixtures may cause damage to light source.



- Non-professional electricians are strictly forbidden to maintain any electrical fault of the lighting fixtures.
- ※ It may damage any electrical component of the lighting fixtures or cause bigger fault.



- Live line maintenance of the lighting fixtures is strictly prohibited; in case of lightning and/or thunderstorm, maintenance of the lighting fixtures is prohibited.
- ※ It may cause electric shock accident.



- Be careful when handling the lighting fixtures.
- ※ Drop or collision may damage the parts or cause personal injury.



- Replace the lead immediately in case the jacket of second cable is damaged.
- ※ It may cause short circuit, electric shock or other failure.



- Don't touch the damaged prism or other glass directly with hands.
- ※ Glass fragments may scratch hands.



- Touching the lighting fixtures with wet hand is strictly prohibited.
- ※ It may cause electric shock or other accident.

1.3 Quality Assurance and Responsibility

Any defect in design, material or workmanship, which may occur during proper and normal use over a period of one year from date of installation but less than 15 months from date of shipment, or within the warranty period of the tender, will be repaired or replaced by manufacturer free of charge. The warranty doesn't cover the failures resulting from lamp burnt out, improper maintenance, installation or operation, or damages due to snow ploughs. Manufacturer shall not be liable to any further claims or particularly claims for damages not affecting the goods themselves.

2.0 Introduction

This manual involves the following series lighting fixtures:

- APP-12----- In-pavement Approach Centerline Light and Cross Bar Light
- APS-12----- In-pavement Approach Side-row Light
- TAE-12----- In-pavement Runway Threshold/ End Light
- THR-12 ----- In-pavement Runway Threshold Light
- THW-12 ----- In-pavement Runway Threshold Wing Bar Light
- END-12 ----- In-pavement Runway End Light
- REL-12 ----- In-pavement Runway Edge Light

Type of In-pavement Approach Centerline Light and Cross Bar Light (APP-12):

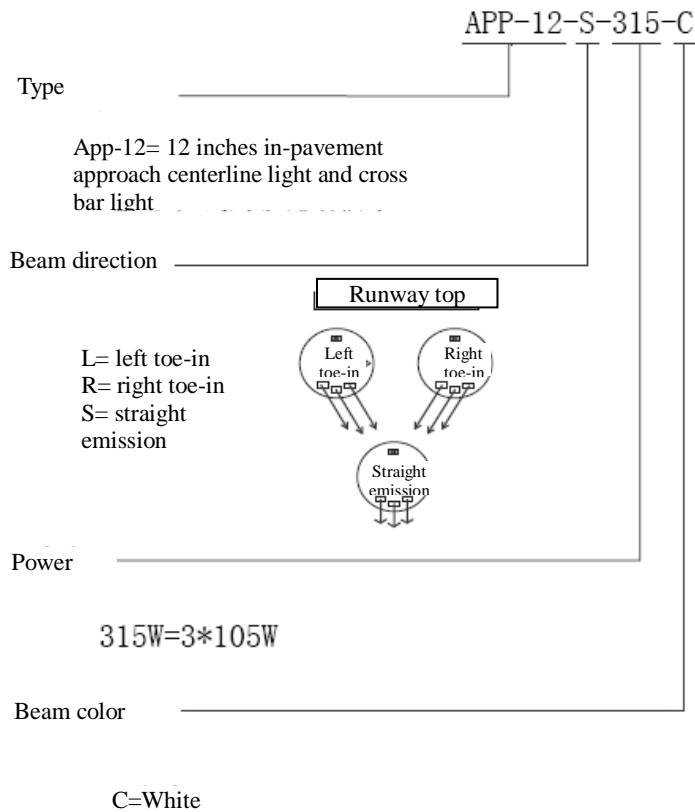

Type of In-pavement Approach Side-row Light (APS-12):

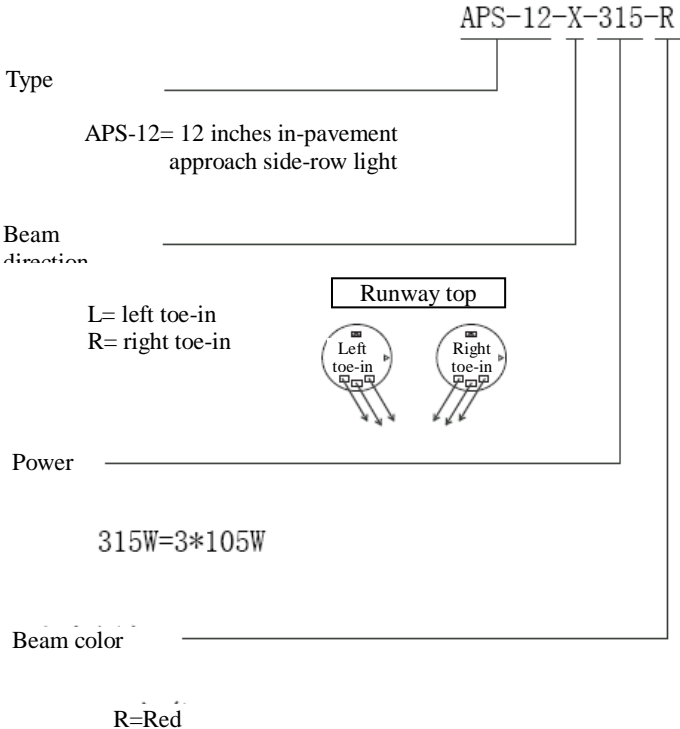

Type of In-pavement Runway Threshold/ End Light (TAE-12):

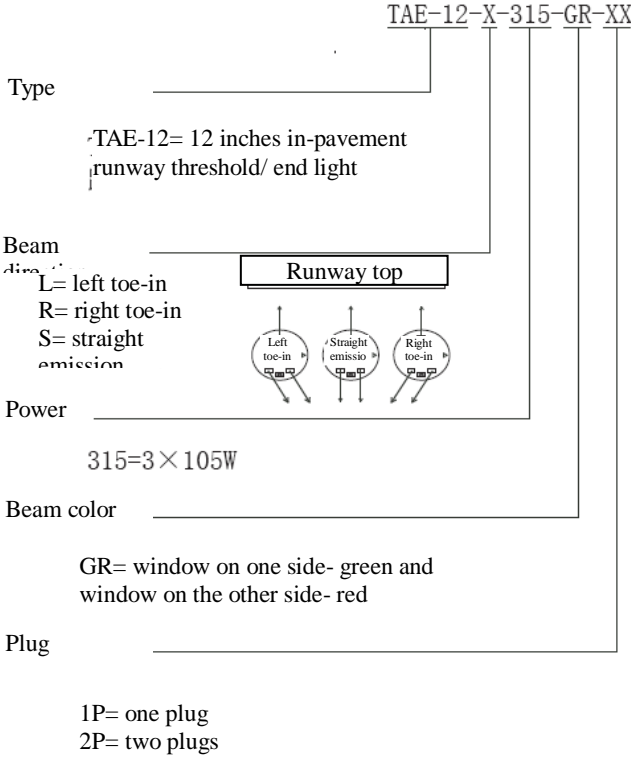

Type of In-pavement Runway Threshold Light (THR-12):

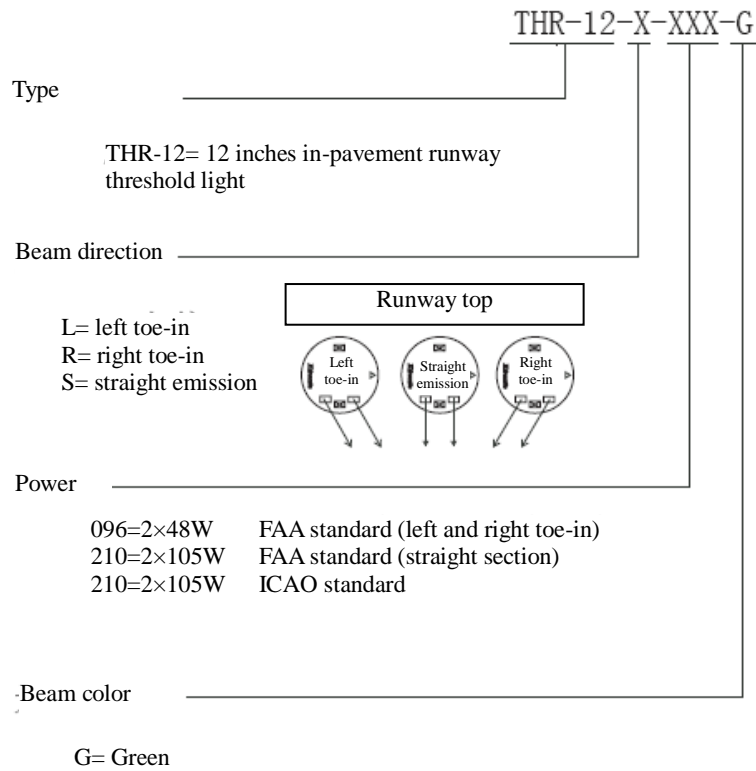

Type of In-pavement Runway End Light (END-12):

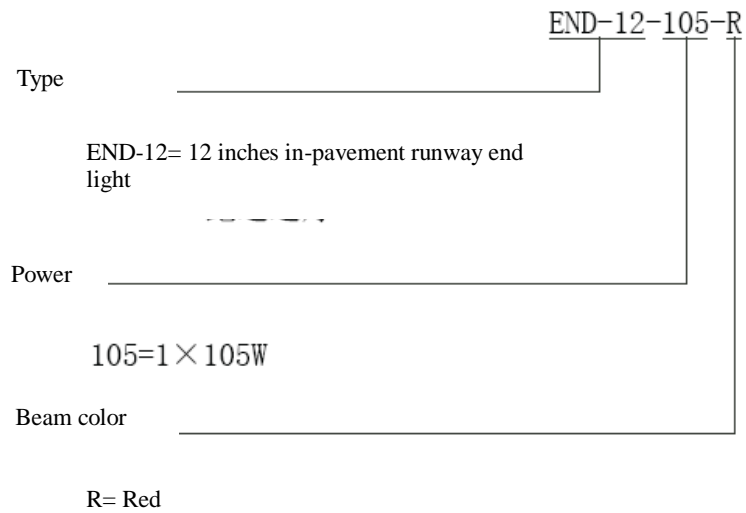

Type of In-pavement Runway Edge Light (REL-12):

REL-12-X-210-XX

Type _____

REL-12= 12 inches in-pavement runway edge light

Beam direction _____

L= left toe-in
R= right toe-in

Power _____

210W=2*105W

Beam color _____

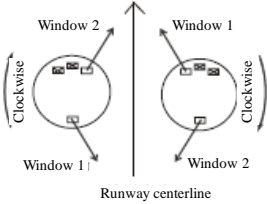

- YC= window 1- yellow and window 2- white
- CY= window 1- white and 1 window 2- yellow
- CC= first and second windows- white
- CR= window 1- white and window 2- red
- RC= window- red and second window- white

2.1 Technical Specifications

This product conforms to the provisions of the following standards or technical specifications. For dated standards or technical specifications, only the edition cited applies. For undated references, the latest edition of the referenced document (including any amendments) applies.

- International Electrotechnical Commission (IEC) TS 61827;
- Convention on International Civil Aviation Annex 14- *Aerodromes* Volume 1;
- International Civil Aviation Organization (ICAO)- *Aerodrome Design Manual*- Part 4: Visual Aids;
- Federal Aviation Administration (FAA) AC150/5345-46;
- Federal Aviation Administration (FAA) EB 67;
- GB/T 7256 *General Requirements of Lighting Fixtures for Civil Airport*;
- Department of Airport of Civil Aviation Administration of China: Advisory Circular, *Technical Requirements for Runway and Taxiway Aid Lighting Fixtures* (AC-137-CA-2015-03)
- Department of Airport of Civil Aviation Administration of China, Advisory Circular, *General Technical Requirements for Civil Airport LED Aid Lighting Fixtures* (AC-137-CA-2015-01)

2.2 Application Environment

- Altitude: below 4,000m;
- Outdoor: -55°C ~ +55°C;
- Relative air humidity: not more than 95%;
- In rain, snow, ice and water;
- Expose to corrosive salt atmosphere
- Basic earthquake intensity VII.
-

2.3 Application Scope

In-pavement approach centerline light and cross bar light, in-pavement approach side-row light, in-pavement runway threshold/ end light, in-pavement runway threshold light, in-pavement runway end light and in-pavement runway edge light for Categories of I, II and III airports.



- Using the lighting fixtures beyond the specified scope is strictly prohibited.
- ※ Application beyond the specified scope will cause damage or risk to any component.

2.4 Technical Parameters

| Description | Type | Rated Power | Life of Light Source |
|---------------------------------|--------------------|-------------|----------------------|
| Approach Centerline Light | APP-12-S-315-C | 3×105W | ≥1,000h |
| Approach Cross Bar Light | APP-12-X-315-C | 3×105W | ≥1,000h |
| Approach Side-row Light | APS-12-X-315-R | 3×105W | ≥1,000h |
| Runway Edge Light | REL-12-X-210-XX | 2×105W | ≥1,000h |
| Runway Threshold Light | THR-12-X-210-G | 2×105W | ≥1,000h |
| | THR-12-X-96-G | 2×48W | ≥1,500h |
| Runway Threshold Wing Bar Light | THW-12-X-315-G | 3×105W | ≥1,000h |
| Runway End Light | END-12-105-R | 105W | ≥1,000h |
| Runway Threshold/ End Light | TAE-12-X-315-GR-XX | 3×105W | ≥1,000h |

2.5 Technical Features

- Proprietary prism structure and manufacturing process, making the optical efficiency excellent;
- Optical parts have self-positioning design and recalibration is unnecessary for replacing the optical components and lamp;
- The filter employs advanced coating technology, with high light transmittance, firm coating and good thermostability;
- The luminous surface of the upper cover of the lighting fixture is flat, and thus it is difficult for ponding and the luminous efficiency is high;
- The upper cover of the lighting fixture employs the constant strength design and forging process, with good mechanical property and high bearing capacity and shock resistance capacity;
- The upper cover of the lighting fixture is smooth, without sharp corner angle to ensure that the aero tyre is not damaged;
- Main body of the lighting fixtures is made of the special high conduction aluminum alloy material and thus the lighting fixtures have good heat dissipation;
- The lamp holder has the suspension design, effectively extend the service life of the lamp;
- Main body of the lighting fixtures is made of aluminum alloy material with special anodizing surface treatment, and all fasteners are made of stainless steel, thus being applicable to all kinds of harsh environment;
- High precision components machining ensures dimensional quality and precision of the lighting fixtures.
- The overall IP rating of the lighting fixtures reaches IP68, which may bear 138KPa internal pressure or water pressure formed by impact of the aircraft on the window;
- The components are of modularized design for common use, which are applicable to various 8 inches LED in-pavement runway lights (6mm), effectively reducing the spare parts inventory.

2.6 Structure

1. Upper cover
2. Prism gasket sleeve
3. Prism
4. Prism gasket
5. Prism pressing bracket
6. Light body gasket
7. Filter
8. Lamp holder
9. Lamp
10. Mounting plate assy
11. Wiring base
12. Inner cover
13. Valve
14. Plug

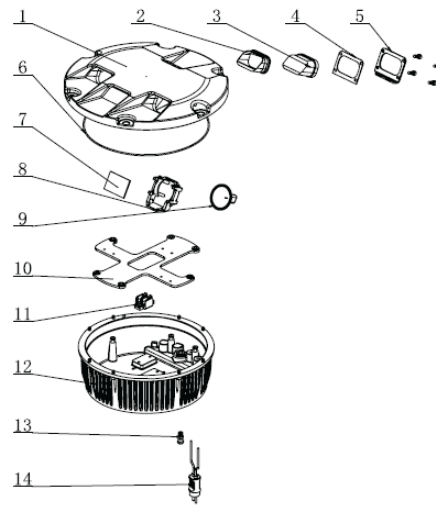

3.0 Installation

Requirements for installation should be learned thoroughly before installation including installation tools and site requirement, etc., to avoid malfunction of the light due to incorrect installation.

3.1 Installation Methods

- On the 12 inches shallow base. (Figure 3-1).
- On the 12 inches deep base. (Figure 3-2).
- The deep base depth may be adjusted according to the customer's requirements.

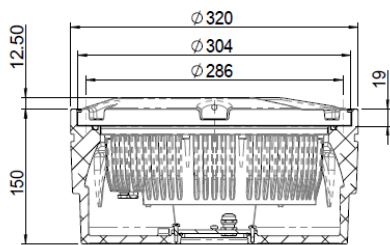

Figure 3-1

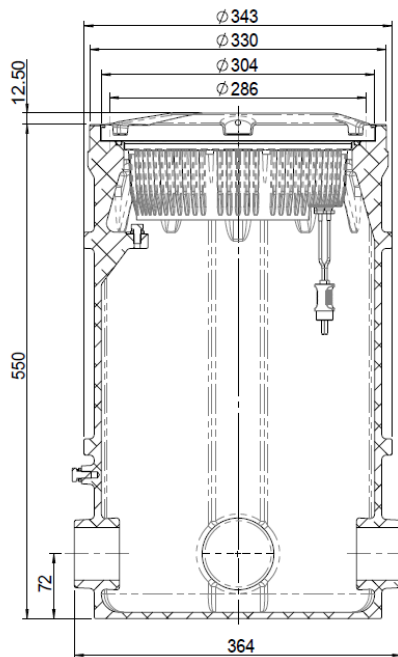
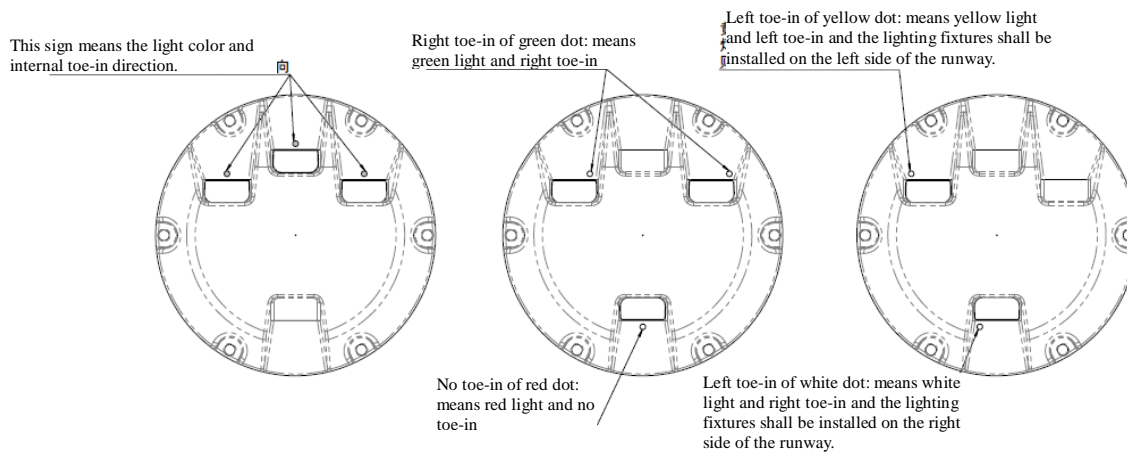

Figure 3-2

3.2 Identification of Different Types of Lighting Fixtures

- The model of each lighting fixture is attached to its bottom.
- The colorful dot identification mark is attached to the light outlet of each lighting fixture, respectively meaning the luminous color and direction of the window where the colorful dot is located.
- According to the specific provisions of FAA, ICAO and CAAC, correctly select the lighting fixtures and ensure their window directions.



- Confirm window color and lighting direction before installation.
- ※ To avoid rework or any other problem.

3.3 Installation Tools

Choosing right tools not only can ensure the correct and reliable installation of the lighting fixtures, but also can reduce unnecessary safety accidents. *Special Tools* listed in the table may be purchased from the manufacturer or any distributor. Universal tools are available on local hardware market. Please pay attention to measurement range during procurement.

- Universal tool: Torque wrench: be used to tighten the screw, which may be used with various sleeve wrenches and directly purchased from various hardware stores, manufacturer or agent.

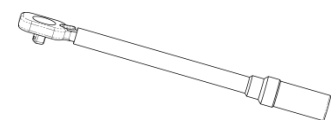

Recommended range is 10-40N·m.

- Universal tool- Torque screwdriver: be used to dismount screw, equipped with PH2 cross screwdriver, and sellable in various hardware stores.

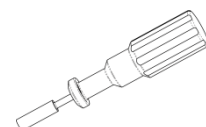

Recommended range is 1-6N.m

3.4 Screw and Torsion

The torque listed in this section is only for reference by maintenance personnel. Correct fastening force of screw can ensure normal operation of the lighting fixtures. If screw is too tight, it will easily damage the lighting fixtures; on the contrary, if screw is easy to fly out, it may cause an accident.

| Serial No. | Screw Type | Tool | Torque |
|------------|------------|--|----------|
| 1 | M10 | Torque wrench with 17# sleeve | 25 N·m |
| 2 | M5 | Force measuring screwdriver with cross screwdriver (PH2) | 3 N·m |
| 3 | M4 | Force measuring screwdriver with cross screwdriver (PH2) | 1.5 N·m |
| 4 | M3 | Force measuring screwdriver with cross screwdriver (PH1) | 0.63 N·m |



- Please use torque wrench or other special tool for installation.
- ※ Informal tools may cause damage to fasteners or personal injury.

3.5 Relevant Configuration of Lighting Fixtures

- 1、 M10×30 screw、 Ø10 spring washer
- 2、 Lighting fixture
- 3、 O- gasket
- 4、 12 inches shallow base

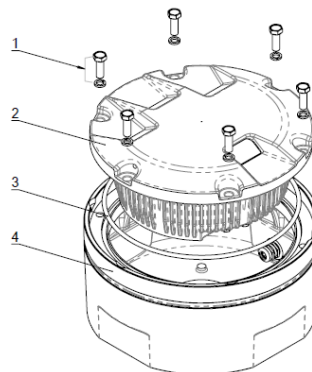

3.6 Installation

The installation process of lighting fixtures includes settings of the pavement mounting hole, wiring, base pre-burial and installation of lighting fixtures. The installation of lighting fixtures will greatly impact their use and service life. The manufacturer recommends that all installers should receive the professional training.

Installation:

1. When installing the lighting fixtures, please first confirm their installation direction: There is scribed line on the base edge and the luminous direction of the lighting fixtures is often parallel to the runway centerline. When the lighting fixture base with the internal toe-in requirements is installed, the internal inclination angle is not considered. The scribed line ^{Base} direction sign parallel to or overlapped with the centerline;

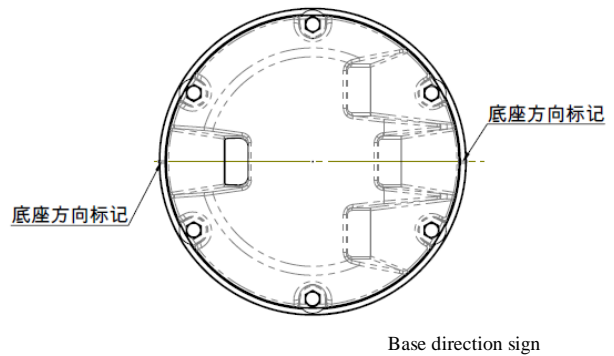

2. Connect the ground lead on the base with the grounding screw on the lighting fixtures.
3. Clean the waste in the seal groove of the base to keep good seal. Put the O-gasket (part No.: 41115) into the working position in the seal groove.
4. Connect the secondary plug of the lighting fixtures with the base receptacle to keep good contact.
5. Load the lighting fixtures into the base, identify the direction, screw the screws into the screw holes in successive and please note the torsion when screwing them.

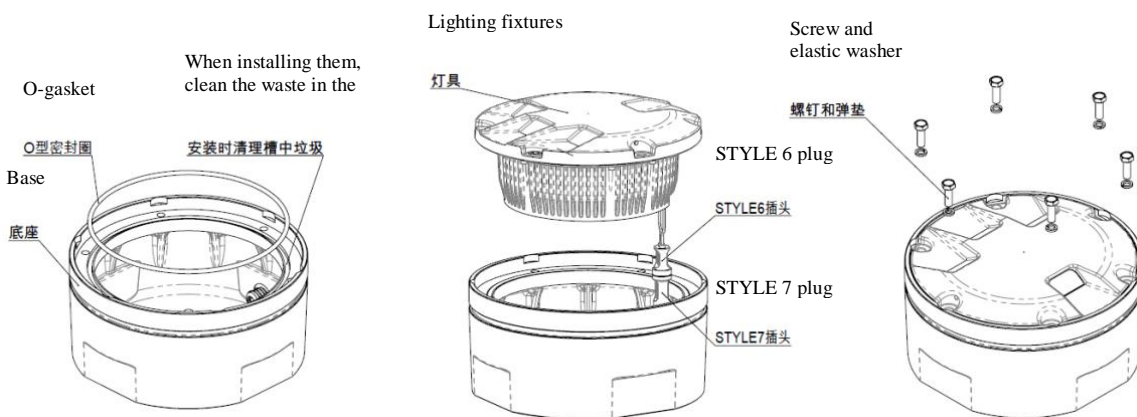

- The ground lead must be connected in strict accordance with the provisions.
- ※ During daily maintenance, the electric shock accident may be caused.



- During installation, the oily lubricating agent shall not be used to lubricate the sealing components.
- ※ The oily lubricant may cause aging or fault of the sealing components.



- The weight of the isolation transformer shall not be directly applied to the lead.
- ※ It may cause cable break, short circuit, drop, injury or other faults.



- Before the lighting fixtures are installed, the dust on the base must be strictly cleaned.
- ※ It may cause leakage between the lighting fixture and base.



- Directly pulling the lead is prohibited when the lighting fixtures are handled.
- ※ It may cause line break, short circuit, drop, injury or other faults.

4.0 Operation and Control

The lighting fixtures are applicable to CCR power supply 6.6A circuit special for airports, which forms a secondary circuit with the lighting fixtures through secondary lead of isolation transformer connected on primary circuit. Due to the use of isolation transformer, the damage of lamp of single lighting fixture will not affect whole series circuit.

4.1 Light Wiring Schematic Diagram

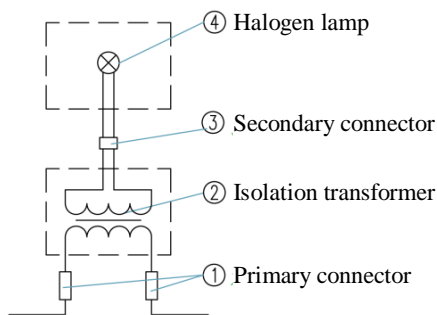

Circuit Diagram of Runway End Light

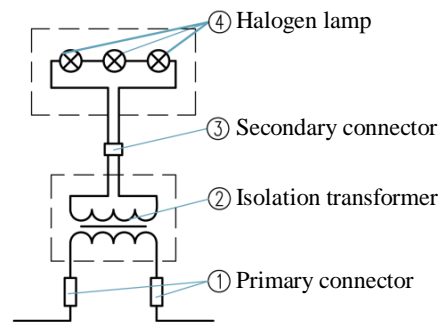

Circuit Diagrams of Approach Centerline Light, Cross Bar Light, Side-row Light, Runway Threshold/ End Light

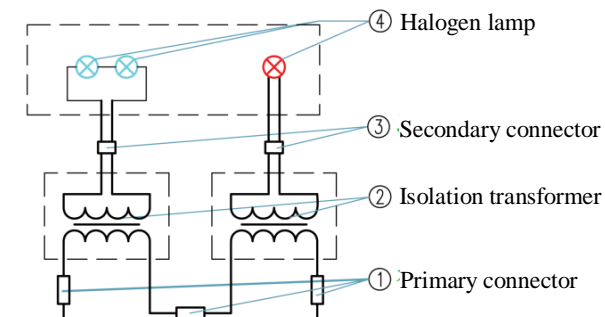

Double Control Circuit Diagram of Threshold/ End Light

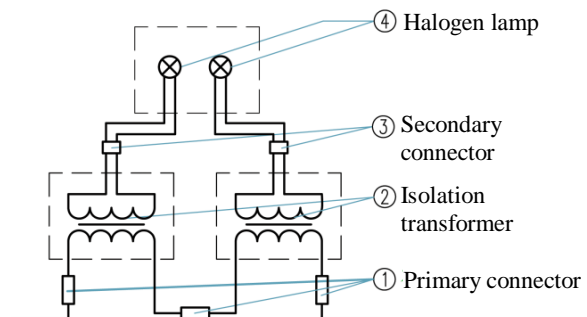

Circuit Diagram of Runway Edge Light

4.2 Light Intensity Adjustment and Control

In actual use, according to weather visibility, light intensity of the lighting fixtures may be adjusted through different current output by CCR, and varies significantly.

If it is used on occasion of lower than rated current (6.6A), it may greatly improve the service life of lamp.

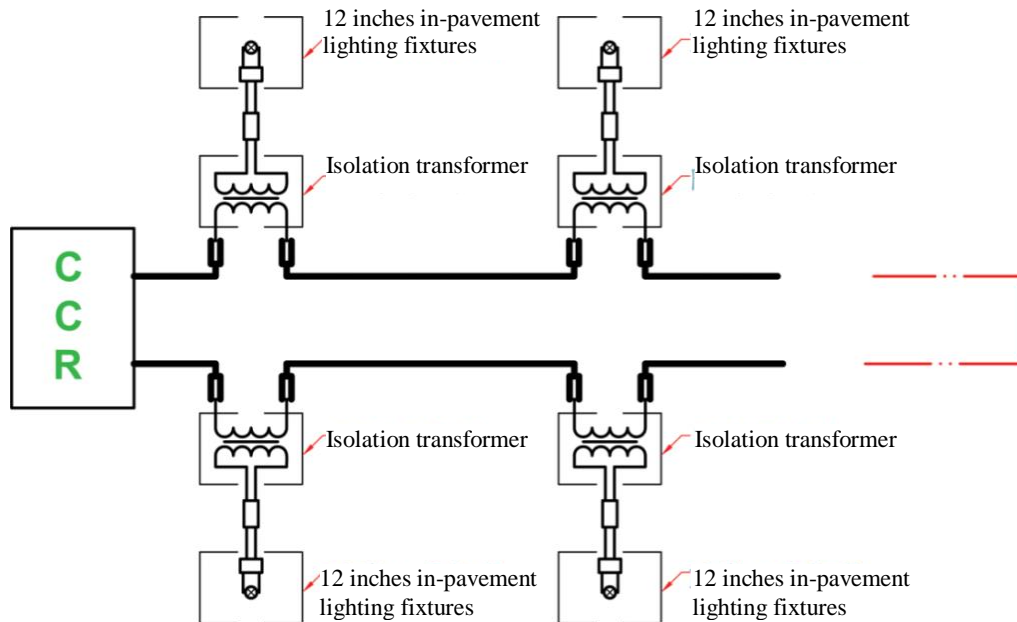

- Using power supply other than CCR is strictly prohibited.
- ※ Other power supply may cause damage to light source or other assy of the lighting fixtures, or even malfunctions of power supply.

5.0 Replacement of Components of Lighting Fixtures

When any damage or failure occurs to any consumable or other component of the lighting fixtures, it is required to timely dismantle the lighting fixtures for replacement of the component. Replacement of components needs to dismantle the lighting fixtures, so any minor error will cause adverse consequences. The manufacturer requires users to attach importance to the following warnings. It is required to be careful during disassembly, to conduct comprehensive inspection of lighting fixtures, to replace some vulnerable parts as required, conduct the air seal test and to ensure the performance of the lighting fixtures after disassembly.



- Replacement of components must be conducted by personnel who have received professional training.
- ※ To avoid various failures of the lighting fixtures.



- It is suggested that maintenance of the lighting fixtures be carried out in lighting station or workshop.
- ※ Any impurities mixed in the lighting fixtures may cause failure of the lighting fixtures.



- Do not touch the coating film filter when cleaning the prism surface.
- ※ It may damage the coating film filter or impact the optimal optical performance of the lighting fixtures.



- When the lighting fixtures are dismantled each time, M10×30 complete set of fasteners shall be replaced.
- ※ The fatigue damage of the screw and elastic failure of the spring washer may cause accident.



- The manufacturer suggests that various gaskets should be replaced during each maintenance of the lighting fixtures.
- ※ Aging and damage of gaskets are the main reasons for the leakage of lighting fixtures.

5.1 How to Dismount the Lighting Fixtures from Base

- Dismount M10×30 screws and spring washer (see Figure 5-1)
- Stretch into the pinch bar hole with two screwdrivers to screw out the lighting fixtures vertically (see Figure 5-2).

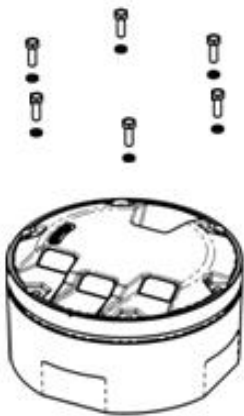

Figure 5-1

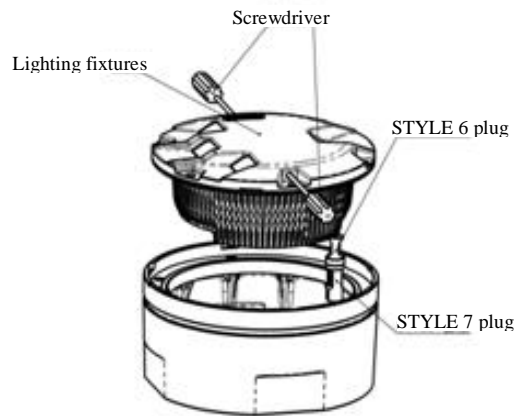

Figure 5-2



- Use the special handle supplied by the manufacturer when the lighting fixture is dismantled.
- ※ Drop of lighting fixtures may cause personal injury.

5.2 How to Open Light Body

- Place the top of the lighting fixtures downwards and dismount 8 M5×12 screws (Figure 5-3);
- Separate the upper cover and inner cover of the lighting fixtures (Figure 5-4).

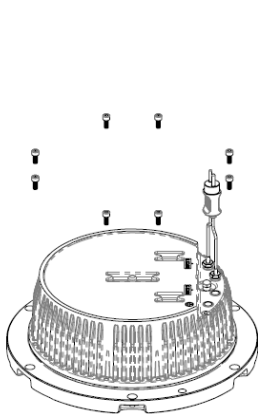

Figure 5-3

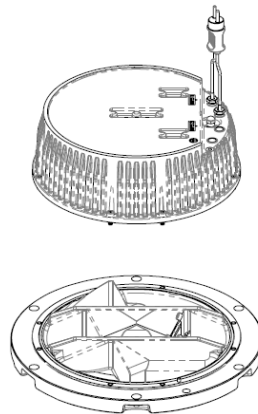

Figure 5-4

5.3 How to Replace Lamp

- Separate the upper cover and inner cover with the method set forth in 5.2;
- Pull out the lamp pin out of the binding post (shown in Figure 5-5);
- Push out the lamp along the sliding chute (shown in Figure 5-6);
- Take out the new lamp, push it in along with the sliding chute with the above-mentioned method, and insert the lamp pin onto the binding post. During this process, please note the lamp installation direction: The printed typeface is on the right hand side (shown in Figure 5-7).

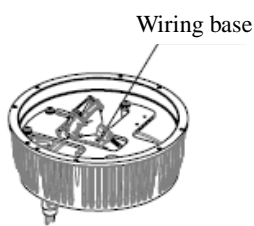

Figure 5-5

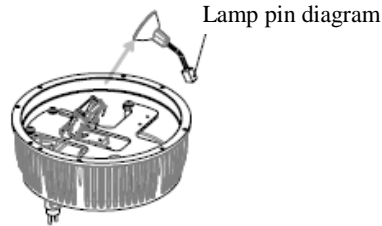

Figure 5-6

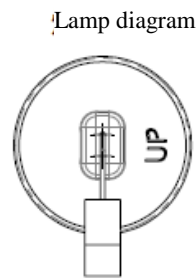

Figure 5-7



- Making sure that the printed typeface on the lamp is on the right hand side.
- ※ Recommendation of the lamp manufacturer is helpful for the normal service life of the lamp.



- Making sure that the lamp is at a correct installation position.
- ※ It may impact the luminous effects of the lighting fixtures.



- Touch the lamp with hands directly is strictly prohibited. The clean white gloves shall be worn during operation.
- ※ The oil and fat on skin may cause crack of the lamp during use.



- Inserting the lamp pin first is strictly prohibited.
- ※ It may cause break of the lamp lead.

5.4 How to Replace Filter

- Dismount the lamp with the method set forth in 5.3;
- Unscrew M4×10 bolts and elastic washer and take down the lamp holder (see Figures 5-8 and 5-9);
- Fetch M3×8 bolts and elastic washer with a cross screwdriver and take down the elastic washer clamping the lamp (see Figure 5-10);
- Take down the used filter, replace a new one and place it in the middle of the lamp holder (see Figures 5-11 and 5-12);
- Insert the elastic washer clamping the lamp and filter to the working position (see Figure 5-13);
- Load the lamp holder with the filter replaced to the working position of the mounting plate of the lighting fixtures (see Figure 5-14);
- Load the lamp onto its bracket with the method set forth in 5.3.

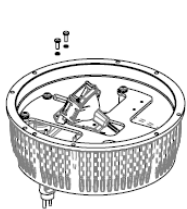

Figure 5-8

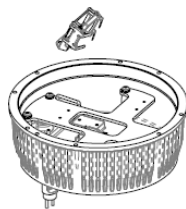

Figure 5-9

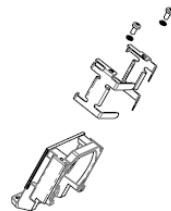

Figure 5-10

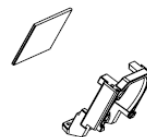

Figure 5-11



Figure 5-12



Figure 5-13



Figure 5-14



- Making sure that the filter coating film is backed to the lamp.
- ※ It may extend the service life of the filter.



- Making sure that the filter is installed at a correct position.
- ※ Otherwise the filter may be crushed during screwing.



- Touching the filter with hands directly is strictly prohibited. During operation, the gloves must be worn.
- ※ The oil and fat on skin may cause crack of the lamp during use.

5.5 12 Inches Mounting Plate and Replacement Instructions

The lighting fixtures of 12 inches in-pavement approach light and cross bar light, in-pavement side-row light, in-pavement threshold light, in-pavement end light, in-pavement threshold/ end light and in-pavement runway edge light have similar structure and the boundary dimension of the mounting plate substrate of their lamp socket is the same. The mounting holes of the lamp holder are located at different design positions. The detailed instructions are given in the following Figures and text below. The users shall carefully read them when maintaining the relevant parts by themselves.

- Mounting plate of approach light 3×105W/6.6A shall apply.

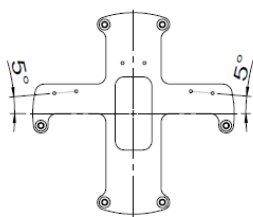

Before installation

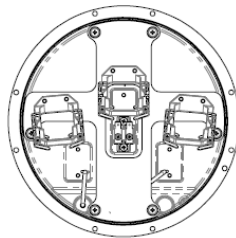

After installation

- Mounting plates of approach cross bar light, side-row light and runway threshold wing bar light

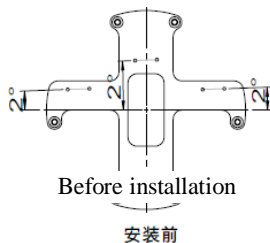

Before installation

安装前

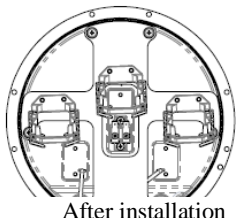

After installation

安装后

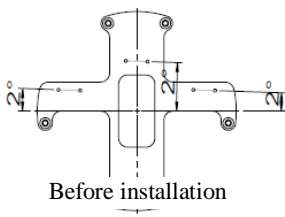

Before installation

安装前

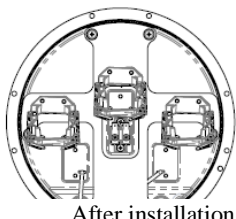

After installation

安装后

The approach cross bar light, side-row light and threshold wing bar light are required to have toe-in 2°. Left toe-in 2° (upper Figure) and right toe-in 2° (lower Figure) are shown respectively. Please identify the requirements when installing them.

○ Mounting plate of runway threshold light, end light and threshold/ end light

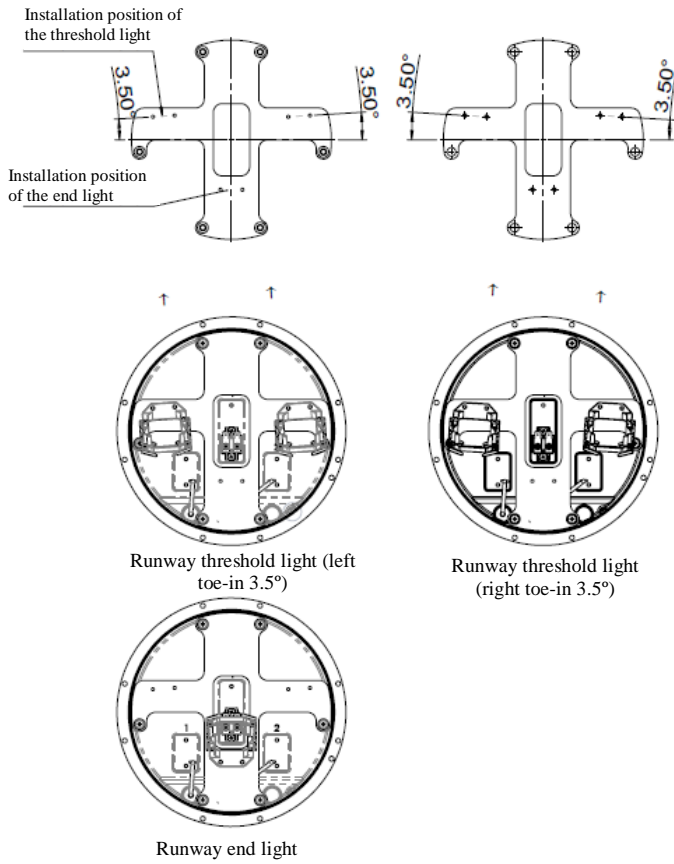

○ Mounting plate of runway edge light

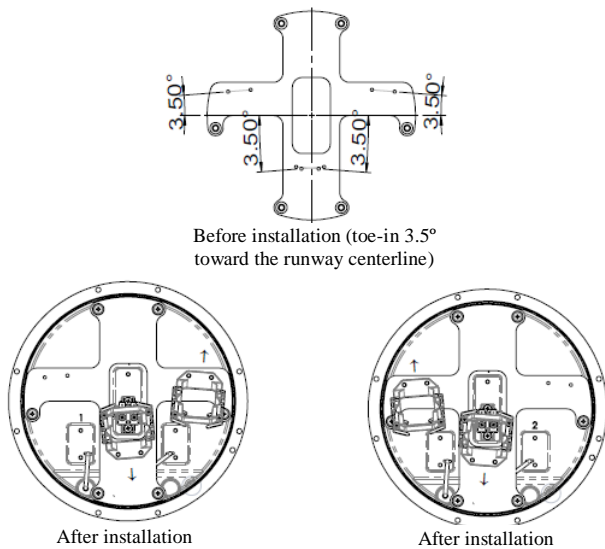

5.6 How to Replace Prism and its Gasket Sleeve

- With the cross screwdriver, dismount M5×12 screws and take down the prism pressing bracket, prism washer, lens and lens gasket sleeve in succession (see Figures 5-15, 5-16 and 5-17);
- Cover the new prism gasket sleeve onto the prism and ensure that the gasket sleeve is uniform (see Figure 5-18);
- Push the prism and its gasket sleeve to the working position on the upper cover. When pushing them, water clean water at the window and wipe the prism surface with the diethyl ether to keep it clean (see Figure 5-19);
- Place the prism pressing bracket and prism washer to the working position and screw the M5×12 screws into the threaded holes after dipping a little of anaerobic adhesive (see Figures 5-20 and 5-21);
- After the gasket sleeve is placed, check whether it is exposed at the window. In case of much exposed, it shall be reloaded according to the above-mentioned process. In case of a small part exposed, cut it with a knife (Figure 5-22).

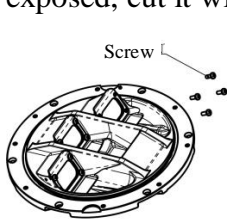

Figure 5-15

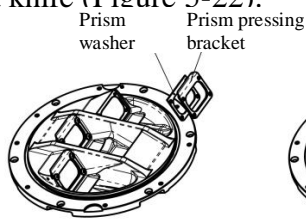

Figure 5-16

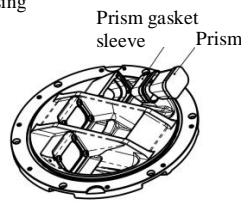

Figure 5-17

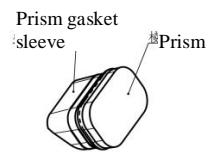

Figure 5-18

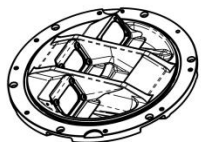

Figure 5-19

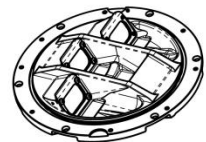

Figure 5-20

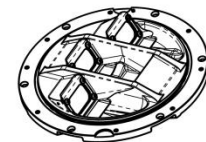

Figure 5-21

In case of a small part exposed, cut it with a knife.



Figure 5-22



- The old rubber gasket sleeve shall not be used repeatedly.
- ※ Aging and damage of the rubber gasket sleeve may cause water seepage and leakage of the lighting fixtures.



- The screw shall be screwed with uniform force at opposite angles.
- ※ Otherwise it may cause damage to the prism or water leakage of the upper cover.



- After the internal fittings of the lighting fixture are replaced each time, check the airtightness of the lighting fixtures.
- ※ Poor assembly may cause leakage of the lighting fixtures.

5.7 How to Replace Gasket

- Dismount the screw connecting the inner cover and upper cover to separate them (see Figure 5-23);
- Take out the old gasket from the seal groove of the upper cover (see Figure 5-24);
- Wash the waste in the seal groove with water or ethyl alcohol to keep the seal groove clean (see Figure 5-25);
- Fetch a new gasket and place it into the seal groove. It shall be in the seal groove naturally (see Figure 5-26);
- Take out the inner cover, make the pin aim at the pin hole and connect the upper cover and inner cover with the screw (see Figure 5-27).

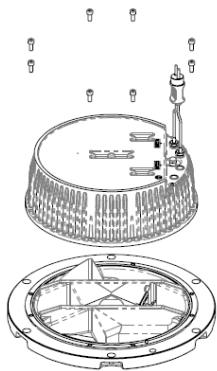

Figure 5-23

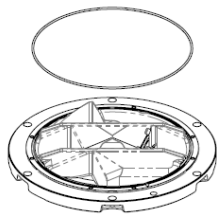

Figure 5-24

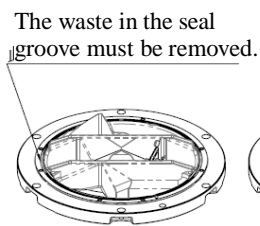

Figure 5-25

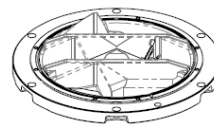

Figure 5-26

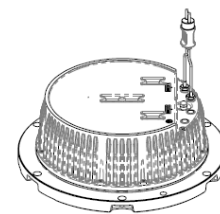

Figure 5-27



- Carefully check the gasket and seal groove to ensure that there are no impurities.
- ※ Impurity inclusion is the main cause of lighting fixture leakage.



- Making sure that the gasket is in the seal groove of the upper cover to prevent it from being cut.
- ※ It may cause lighting fixture leakage.



- ※ The force shall be uniformly applied to the screws at the opposite angles, which shall be screwed gradually.
- ※ Improper assembly cause in water seepage of the lighting fixtures.

5.8 Airtight Test of Lighting Fixtures

- Unscrew the valve cap at the lighting fixture bottom (see Figure 5-28).
- Prepare 138Kpa air source (the air pressure shall not be greater than 150Kpa) and applicable air gun (air tube), inflate the air by aiming at the valve until the air pressure in the lighting fixture meets the requirements (Figure 5-29). Put this lighting fixture into the water with the depth of 76mm for at least 1min and check whether there are bubbles under the state of static water surface. If not, it means that the sealing property of the lighting fixture is good, otherwise it shall be deemed that the lighting fixture has leakage.
- After detection, release the air pressure in the lighting fixture with the air valve of the valve core, re-screw the valve cap and put it into use (Figure 5-30). In case of leakage, check the causes according to the previous prompts and repeat the whole lighting fixture disassembly and assembly process or return it to the factory for maintenance.

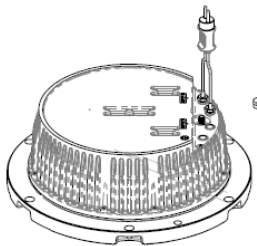

Figure 5-28

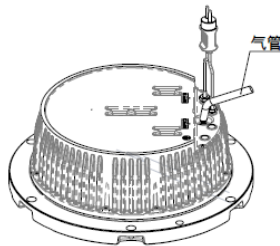

Figure 5-29

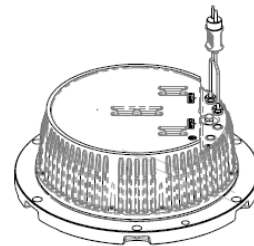

Figure 5-30



- After installation, the leakage test must be performed according to the requirements.
- ※ Improper assembly may cause leakage of the lighting fixtures.



- Unscrewing the valve is prohibited, when the valve cap is unscrewed.
- ※ Otherwise it may cause leakage of the lighting fixtures.

6.0 Maintenance of Lighting Fixtures

Suggestions for daily maintenance provided in this section are only for reference. Airports may formulate their own daily maintenance guidelines with reference to other provisions or maintenance experience of airport staff; the manufacturer does not provide any hard-and-fast rules.

Maintenance of the lighting fixtures for airports shall be conducted by professionals as stated in 1.0 Foreword.

6.1 Daily Maintenance

| Interval | Check | Activity |
|--------------------|--|--|
| Every day | No light output or flashing | Replace the lamp |
| | Light output is lower | <ol style="list-style-type: none"> 1. Clean the prism surface if it is dirty. 2. Check deviation or moisture of the lighting fixtures. 3. Check aging or displacement of LED. |
| Every week | Obstacles to light output channel | Clean the path and prism surface. |
| Every month | Existence of moisture and water (Visual check of internal surface of prism) | <ol style="list-style-type: none"> 1. Open the body. 2. Clean, dry and check. 3. Replace the gasket of the light body and other parts damaged. |
| Every two months | Tighten the screws | <p>Check whether screw for tightening light body is locked.</p> <p>Use the tools such as wrench and sealant by referring to the Table in Section 3.4.</p> |
| Every half a year | Water in the base | <ol style="list-style-type: none"> 1. Pump out the water in the base. 2. Move and dismantle it and observe the damage to the lighting fixtures by water. 3. Dispose of the water inlet. |
| After snow removal | Damage to lighting fixtures | <ol style="list-style-type: none"> 1. Replace seriously damaged light. |
| After snow removal | Light output is lower | <ol style="list-style-type: none"> 1. Sweep the snow on the window with a powerful sweeper. 2. Clean the prism surface if it is dirty. 3. Check deviation or moisture of the lighting fixtures. 4. Check the lamp aging or displacement. |

6.2 Regular Spot Check and Troubleshooting

| Serial No. | Failure Phenomenon | Possible Reasons | Countermeasures |
|------------|---------------------------------|-------------------------------|------------------------------|
| 1 | No light output | The lamp is damaged. | Replace the lamp. |
| 2 | The lighting fixtures is darker | The prism surface is dirty. | Clean the prism surface. |
| 3 | Existence of moisture and water | Damage to the prism or gasket | Replace the prism or gasket. |



- The manufacturer suggests that times of daily maintenance should be increased in rainy season.
- ※ To ensure normal operation of lighting fixtures.



- The manufacturer suggests that the lighting fixtures should be systematically replaced when the service life of the LED lamp reaches 80%.
- ※ To ensure the consistency of light intensity of whole circuit.



- It is necessary to use torque wrench. Power wrench is strictly prohibited.
- ※ Otherwise, it may damage screw and thread, and thus cause an accident.

7.0 List of Components and Ordering of Spare Parts and Accessories

The list of parts of this product and relevant ordering information of the spare parts and accessories are shown in the Table of this Chapter. The manufacturer accepts to order in a manner of component or separate ordering of the parts. When ordering, please contact the manufacturer or deal according to the ordering No. listed in the Table. The manufacturer recommends to purchase some key parts from the original manufacturer to ensures all indexes of the lighting fixtures.

List of components and spare articles:

| Structure No. | Component Name | Order No. | Remarks |
|---------------|--|-----------|--|
| 1 | Upper cover | 921331/ | Upper cover (U3) assy/ |
| | | 921341/ | Upper cover (B3) assy/ |
| | | 921351/ | Upper cover (U2) assy/ |
| | | 921361/ | Upper cover (B2) assy/ |
| | | 921371 | Upper cover (U1) assy/ |
| 2 | Prism gasket sleeve | 43107 | Prism gasket sleeve (H33.8) |
| 3 | Prism | 31141 | Prism (enlarged type) |
| 4 | Prism gasket | 43307 | Prism gasket (62×47) |
| 5 | Prism pressing bracket | 43208 | Prism pressing bracket (62×55) |
| 6 | Light body gasket | 41135 | O- gasket 228.27×2.62 |
| 7 | Filter | 31316-R/ | Filter (coating film)53×36- red/ |
| | | 31316-G/ | Filter (coating film)53×36- green/ |
| | | 31316-Y | Filter (coating film)53×36- yellow |
| 8 | Lamp holder | 942133 | 28° lamp holder (combination) |
| 9 | Lamp | L64339/ | 105W 6.6A/ |
| | | L64337 | 48W 6.6A |
| 10 | Mounting plate | | Mounting plate of approach centerline lamp socket/ |
| | | 41441/ | |
| | | 41444/ | Mounting plate of runway edge light/ |
| | | 41445/ | Right mounting plate of approach cross bar light/ |
| | | 41446/ | Left mounting plate of approach cross bar light/ |
| | | 41447/ | Mounting plate of runway threshold/ end light |
| | | 41448/ | Left mounting plate of runway threshold end light |
| 41449 | Right mounting plate of runway threshold end light | | |
| 11 | Wiring base | 941201 | Ceramic wiring base assy (embedded type) |
| 12 | Inner cover | 21421/ | Inner cover (12) |
| 13 | Valve | 941801 | Valve assy |

| | | | |
|----|------------------|---|--|
| 14 | Plug | HT70603 | Secondary cable connector-A6 twin-core plug (flat)- high temperature |
| | Upper cover assy | 921956/ 921953/ 921955/ 921951/ 921952/ 921954 | Upper cover (U3 including prism) assy (centerline and cross bar light and wing bar light)/ Upper cover (B3 including prism) assy (runway threshold/ end light)/ Upper cover (U2 including prism) assy (runway threshold)/ Upper cover (B2L including prism) assy (runway edge light)/ Upper cover (B2R including prism) assy(runway edge light)/ Upper cover (U1 including prism) assy (runway end light) |
| | Inner cover assy | 921426/ 921422/ 921421/ 921425 | Inner cover assy 1P-1 (runway end light)/ Inner cover assy 1P-2 (runway threshold light and runway edge light)/ Inner cover assy 1P-3 (3) (centerline and cross bar light, wing bar light)/ Inner cover assy 1P-3 (4) (runway threshold/ end light) (Inner cover assy includes wiring base, valve, connecting wire and seal assy) |

List of supporting accessories of this product is as follows (needing additional order):

| Serial No. | Order No. | Description |
|------------|-------------|---|
| 1 | 927151 | 12 inches shallow base assy (side entry) |
| 2 | 927156 | 12 inches shallow base assy (bottom entry) |
| 3 | 82732X | Deep base (H550) assy For the opening direction, please contact us. |
| 4 | 70703 | Secondary receptacle A7 |
| 5 | 41115 | 12 inches base O- gasket |
| 6 | ITF-100-066 | Isolation transformer 100W |
| 7 | ITF-300-066 | Isolation transformer 300W |



- Please purchase various spare parts from us when they may not meet the requirements.
- ※ Parts of other brands may not meet the requirements of the lighting fixtures.

8.0 Packaging, Transportation and Storage

8.1 Packaging and Weight

Packaging: 2 pcs / box

Gross weight: 6.5 KG / box

Volume: 30*30*150

Packaging: 1 pcs / box (including 12 inches shallow base)

Gross weight: 11 KG / box

Volume: 350*350*185

8.2 Transportation Mode

Well packed products may be transported in three modes- railway, highway and air according to factors such as transportation distance, quantity of lights and delivery cycle.

8.3 Storage

This product shall be stored in a place which is dry, well ventilated and far away from heat source and has no caustic gas. Custody should be checked on a regular basis.

The final right to interpret this manual is reserved by Airsafe Airport Equipment Co., Ltd.

Thanks for your purchasing and using AIRSAFE product!

Address: No. 38, Anxin Road, Xuhang Town, Jiading
District, Shanghai, China
Postal Code: 201800
Tel.: 021-53540453
Fax: 021-63643114
E-mail: sales@airsafe.com.cn