

## **EUL Series of Elevated Uni-directional Lighting Fixtures**

**EUL-AP Approach Light, EUL-AP Side-row Light, EUL-TH Runway  
Threshold Light, EUL-TH Threshold Wing Bar Light, EUL-ED End Light  
and EUL-SB Elevated Stop Bar Light**

### **Operation Manual**



Please read this manual carefully before construction, installation and operation of the product.  
Please keep this manual properly for further reference.

This manual is subject to change without prior notice.

Airsafe Airport Equipment Co., Ltd.

## Revision Description

No.	Description	Version No.	Revised by	Approved by	Date
1	First release	V1.0	Y.YH	C.SY	Feb. 15, 2008
2	Type and composing adjustment added	V1.1	Z.H	X.CL	Nov. 11, 2016

## Table of Content

Table of Content .....	3
1.0 Foreword.....	4
1.1 Illustrations and Meanings.....	5
1.2 Safety Rules and Notices .....	6
1.3 Quality Assurance and Responsibility .....	7
2.0 Introduction .....	8
<b>2.1 Technical Specifications</b> .....	10
<b>2.2 Application Environment</b> .....	11
<b>2.3 Application Scope</b> .....	11
2.4 Technical Parameters .....	11
2.5 Technical Features .....	12
2.6 Structure.....	13
<b>3.0 Installation</b> .....	14
3.1 Installation Tools.....	14
3.2 Screw and Torsion .....	14
3.3 Flange and Frangible Pole .....	15
3.4 Installation Methods .....	16
3.5 Installation Steps.....	17
3.6 Adjustment of Horizontal and Vertical Beam Angles of Lighting Fixtures .....	18
3.6.1 Operating parts for adjusting lighting fixtures .....	18
3.6.2 Corrector operating parts as shown in Figure .....	18
3.6.3 Corrector installation .....	19
3.6.4 Adjustment of horizontal beam angle: .....	19
3.6.5 Adjustment of vertical beam angle: .....	20
<b>4.0 Replacement of Components of Lighting Fixtures</b> .....	21
4.1 Replace Lamp .....	22
<b>5.0 Operation and Control</b> .....	23
<b>5.1 Light Wiring Schematic Diagram</b> .....	23
5.2 Light Intensity Adjustment and Control .....	23
<b>6.0 Maintenance of Lighting Fixtures</b> .....	24
6.1 Daily Maintenance.....	24
6.2 Regular Spot Check and Troubleshooting .....	25
7.0 List of Components and Ordering of Spare Parts and Accessories.....	26
<b>8.0 Packaging, Transportation and Storage</b> .....	28
<b>8.1 Packaging and Weight</b> .....	28
<b>8.2 Transportation Mode</b> .....	28
<b>8.3 Storage</b> .....	28

## **1.0 Foreword**

ICAO *Airport Service Manual* Part 9 “Airport Maintenance Practices” and FAA AC150/5345-26 *Maintenance of Airport Visual Aid Facilities* are the highest criterions for site installation and maintenance of such lighting fixtures. This manual was compiled with considerable reference to these two criterions.

The content stated in this manual is absolutely important, so construction personnel must read it carefully before construction. After properly understanding the entire content of this manual, construction personnel should carry out the construction in strict accordance with the methods specified herein, to ensure that the product is safely and properly installed in place.

Routine airport maintenance personnel should carry out the routine maintenance in strict accordance with the methods specified by relevant provisions, to ensure that the lighting fixtures are in the best operation condition.

Related personnel must strictly follow safety criterion. Any personnel without specialized training is strictly forbidden to touch the lighting fixtures and devices. Live line work should be avoided under any circumstances. Construction or maintenance personnel should get acquainted with first-aid knowledge, in case of any unexpected events.

## 1.1 Illustrations and Meanings

- Following illustrations will appear in this manual where necessary to remind or warn construction or maintenance personnel.
- Please continue reading the subsequent content of this manual after properly understanding the meanings of these illustrations.



- To remind that the behavior may cause serious injury or death.
- ※ Detailed description will be given in the box.



- To remind that the behavior may cause injury to people or damage to product.
- ※ Detailed description will be given in the box.



- To notify that the behavior is prohibited.
- ※ Detailed description will be given in the box.

## 1.2 Safety Rules and Notices



- Using the light fixtures outside of airport is strictly prohibited.
- ※ Inadequate maintenance or casual touch will cause light faults.



- Using power supply other than CCR is strictly prohibited.
- ※ It may damage the lighting fixtures and even cause fault of the power supply.



- The frangible pole is equipped at the lower part of the light pole. When it is installed, upper part of the frangible pole bearing the force is prohibited.
- ※ The frangible pole may be broken.



- Making sure that CCR is on power-off state before the installation or maintenance of the lighting fixtures.
- ※ Current surge produced during the installation of the lighting fixtures may cause damage to light source.



- Non-professional electricians are strictly forbidden to maintain any electrical fault of the lighting fixtures.
- ※ It may damage any electrical component of the lighting fixtures or cause bigger fault.



- Be careful when handling the lighting fixtures.
- ※ Drop or collision may damage the parts or cause personal injury.



- Replace the lead immediately in case the jacket of second cable is damaged.
- ※ It may cause short circuit, electric shock or other failure.



- Don't touch the damaged optical cover or other glass directly with hands.
- ※ Glass fragments may scratch hands.



- Touching the lighting fixtures with wet hand is strictly prohibited.
- ※ It may cause electric shock or other accident.

### **1.3 Quality Assurance and Responsibility**

Any defect in design, material or workmanship, which may occur during proper and normal use over a period of one year from date of installation but less than 15 months from date of shipment, or within the warranty period of the tender, will be repaired or replaced by manufacturer free of charge. The warranty doesn't cover the failures resulting from lamp burnt out, improper maintenance, installation or operation, or damages due to snow ploughs. Manufacturer shall not be liable to any further claims or particularly claims for damages not affecting the goods themselves.

## 2.0 Introduction

This manual involves the following series lighting fixtures:

EUL-AP-----Elevated Approach Centerline Light

EUL-SR-----Elevated Approach Side-row Light

EUL-TH-----Elevated Runway Threshold Light

EUL-THW-----Elevated Runway Threshold Wing Bar Light

EUL-ED-----Elevated Runway End Light

EUL-SB-----Elevated Stop Bar Light

Type of Elevated Approach Centerline Light (EUL-AP):

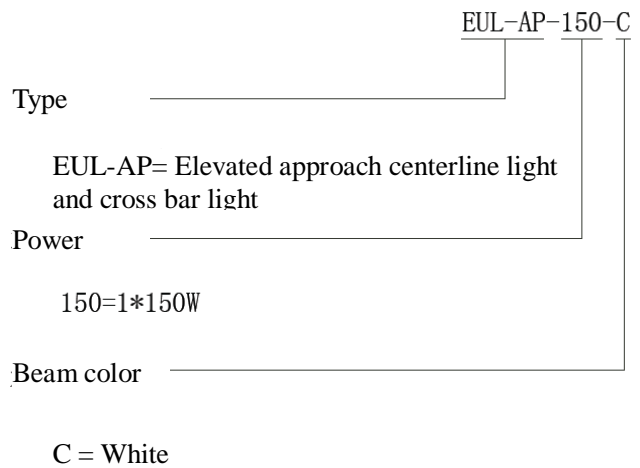

Type of Elevated Approach Side-row Light (EUL-SR):

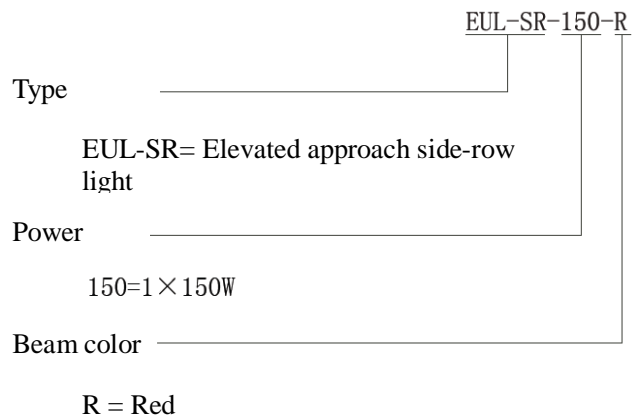



Type of Elevated Runway Threshold Light (EUL-TH):

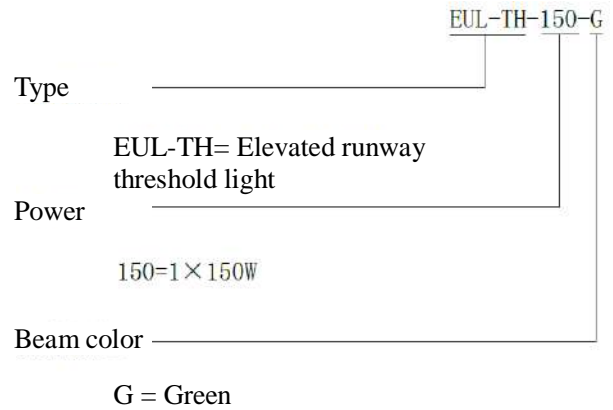

Type of Elevated Runway Threshold Wing Bar Light (EUL-THW):

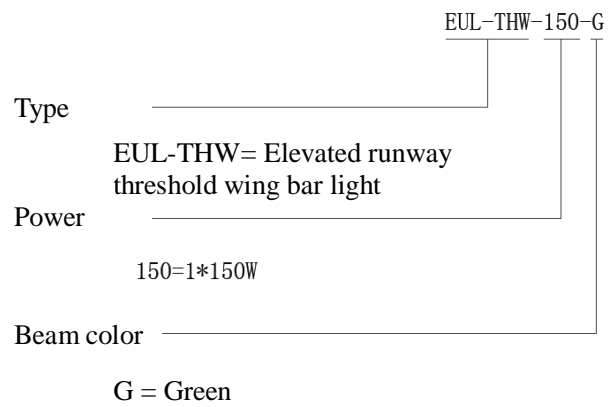

Type of Elevated Runway End Light (EUL-ED):

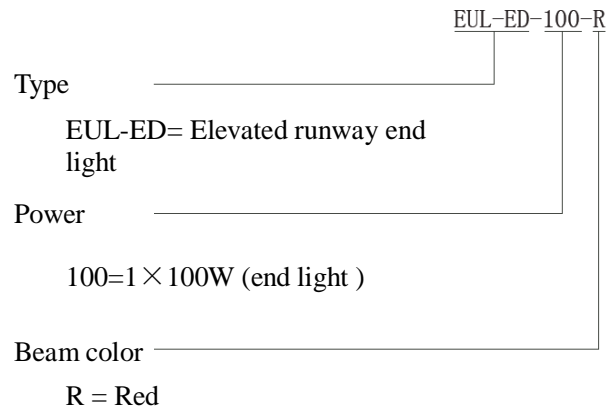

Type of Elevated Stop Bar Light (EUL-SB):

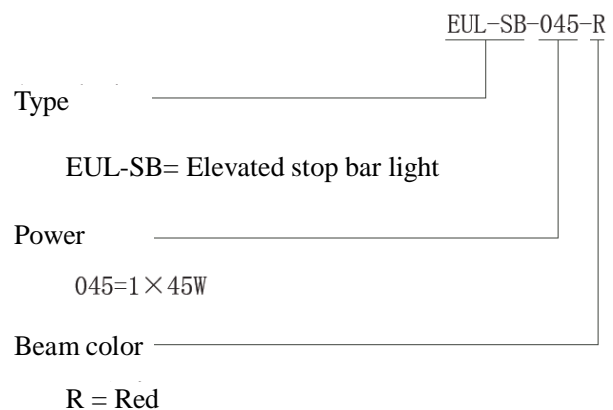

## 2.1 Technical Specifications

This product conforms to the provisions of the following standards or technical specifications. For dated standards or technical specifications, only the edition cited applies. For undated references, the latest edition of the referenced document (including any amendments) applies.

- International Electrotechnical Commission (IEC) TS 61827;
- Convention on International Civil Aviation Annex 14- *Aerodromes* Volume 1;
- International Civil Aviation Organization (ICAO)- *Aerodrome Design Manual- Part 4: Visual Aids*;
- Federal Aviation Administration (FAA) AC150/5345-46;
- Federal Aviation Administration (FAA) EB 67;
- GB/T 7256 *General Requirements of Lighting Fixtures for Civil Airport*;
- Department of Airport of Civil Aviation Administration of China: Advisory Circular, *Technical Requirements for Runway and Taxiway Aid Lighting Fixtures* (AC-137-CA-2015-03) ;
- Department of Airport of Civil Aviation Administration of China, Advisory Circular, *General Technical Requirements for Civil Airport LED Aid Lighting Fixtures* (AC-137-CA-2015-01) ;

## 2.2 Application Environment

- Altitude: below 4,000m;
- Outdoor: -55°C ~ +55°C;
- Relative air humidity: not more than 95%;
- In rain, snow, ice and water;
- Expose to corrosive salt atmosphere.
- Basic earthquake intensity VII.

## 2.3 Application Scope

Elevated approach centerline light, elevated approach side-row light, elevated runway threshold light, elevated runway threshold wing bar light, elevated runway end light and elevated stop bar light for Category I, II and III airports.



- Using the lighting fixtures beyond the specified scope is strictly prohibited.
- ※ Application beyond the specified scope will cause damage or risk to any component.

## 2.4 Technical Parameters

Description	Type	Rated Power	Power Factor
Elevated Approach Centerline Light	EUL-AP-150-C	150W	≥1,500h
Elevated Approach Side-row Light	EUL-SR-150-R	150W	≥1,500h
Elevated Runway Threshold Light	EUL-TH-150-G	150W	≥1,500h
Elevated Runway Threshold Wing Bar Light	EUL-THW-150-G	150W	≥1,500h
Elevated Runway End Light	EUL-ED-100-R	100W	≥1,500h
Elevated Stop Bar Light	EUL-SB-045-R	45W	≥1,500h

## 2.5 Technical Features

- Proprietary optical design and the lighting fixtures still have full-optical output when part of the front glass is sheltered;
- The filter employs advanced coating technology, with high light transmittance, firm coating and good thermostability;
- Optical parts have self-positioning design and recalibration is unnecessary for replacing the optical components and lamp;
- International standard PK30D preset focus lamp has accurate positioning and high light distribution accuracy;
- Proprietary reflector design and cold light cup process treatment. The temperature shock will not result in crack of the front glass and filter;
- Compact structure, attractive appearance, small windward area and strong wind resistance capability;
- Main body of the lighting fixtures is made of aluminum alloy material with special anodizing surface treatment, and all fasteners are made of stainless steel, thus being applicable to all kinds of harsh environment;
- High precision components machining ensures dimensional quality and precision of the lighting fixtures;
- Forged frangible device with precise machining, complying with FAA standards and ensuring stable and reliable performance;
- The overall IP rating of the lighting fixtures reaches IP65, and it is difficult for the dust to be deposited in them;
- Lighting fixtures may be connected with 1 inch or 2 inches frangible pipe, which is firm and reliable and is easy installed;
- A calibrator may be directly installed on the light body, with easy and accurate installation and calibration;
- Lighting fixtures may be maintained without tool, which are easily dismantled and the lamp may be replaced with a hand on site;
- The components are of modularized designed for common use, which are applicable to the elevated lighting fixtures of the uni-directional halogen light, effectively reducing the spare parts inventory.

## 2.6 Structure

- 1 Cover bracket
- 2 Optical cover
- 3 Filter
- 4 LED lamp assy
- 5 Reflector
- 6 Light body
- 7 Lamp holder
- 8 Lamp
- 9 Body gasket
- 10 Rear Cover
- 11 Hinge pin of rear cover
- 12 Front adjusting screw
- 13 Check ring
- 14 Hinge pin of light body
- 15 Rear adjusting screw
- 16 Side lock screw
- 17 Body gasket
- 18 Set screw
- 19 Fixed base of terminal block
- 20 Waterproof gland
- 21 Plug

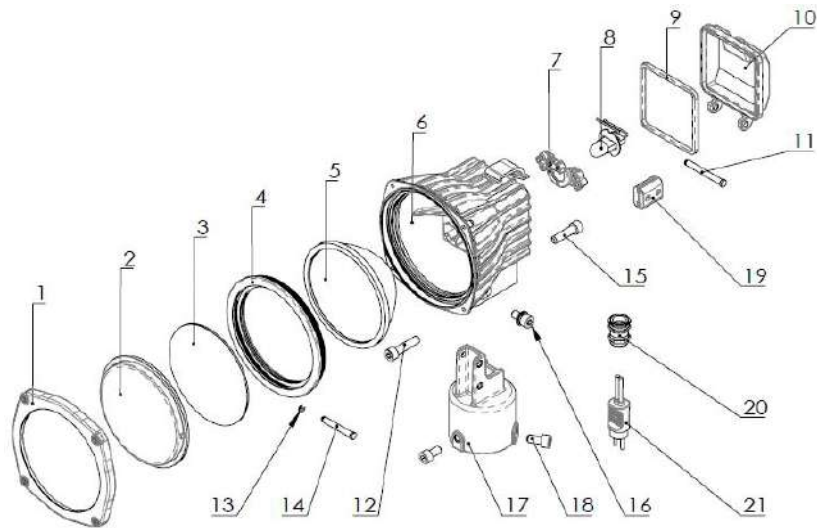

### 3.0 Installation

Requirements for installation should be learned thoroughly before installation including installation tools and site requirement, etc., to avoid malfunction of the light due to incorrect installation.

#### 3.1 Installation Tools

Choosing right tools not only can ensure the correct and reliable installation of the lighting fixtures, but also can reduce unnecessary safety accidents. *Special Tools* listed in the table may be purchased from the manufacturer or any distributor. Universal tools are available on local hardware market. Please pay attention to measurement range during procurement.

- Special tool- Elevated light nut wrench: be used to dismount the lighting fixtures, and available directly from the manufacturer or any distributor.
- Universal tool- Torque screwdriver: be used to dismount screw, equipped with PH2 cross screwdriver, and sellable in various hardware stores. Recommended range is 1-6N.m.

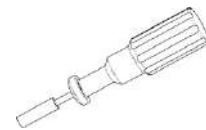

#### 3.2 Screw and Torsion

The torque listed in this section is only for reference by maintenance personnel. Correct fastening force of screw can ensure normal operation of the lighting fixtures. If screw is too tight, it will easily damage the lighting fixtures; on the contrary, if screw is easy to fly out, it may cause an accident.

Serial No.	Screw Type	Tool	Torque
1	M8 Screw	Socket head wrench	5 N·m
2	M4 Screw	Socket head wrench	1.5 N·m



- Please use torque wrench or other special tool for installation.
- ※ Informal tools may cause damage to fasteners or personal injury.

### 3.3 Flange and Frangible Pole

- This Operation Manual does not define the installation of the flange. For the technical support, please contact the construction party and the dimension of the chassis installed, please see Figure below:

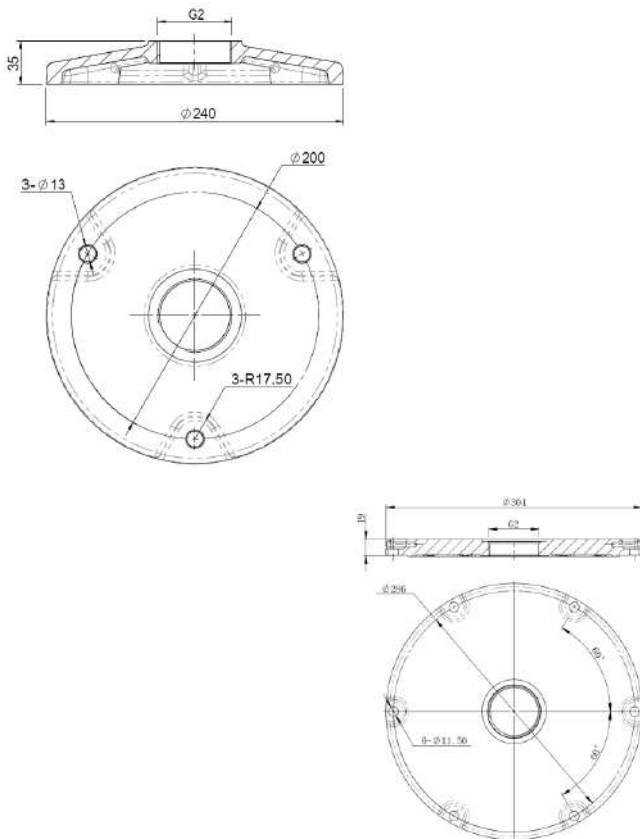

- Installation of optional parts:

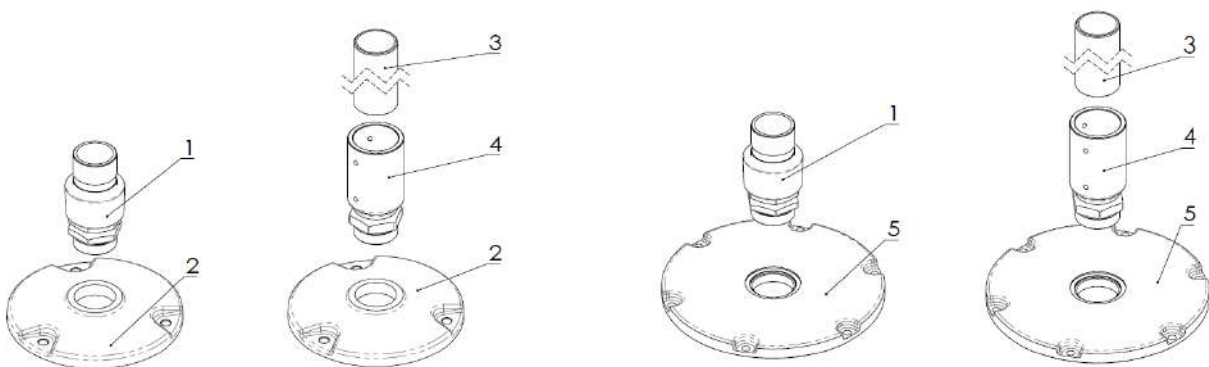

- |                            |                                   |               |
|----------------------------|-----------------------------------|---------------|
| 1. 2 inches frangible part | 3. Ø60 extension pole             | 5. Flange 304 |
| 2. Flange 240              | 4. 2 inches socket frangible pole |               |

### 3.4 Installation Methods

Method 1: Mast installation;

Method 2: Installation of extension pole;

Method 3: 12 inches deep bucket installation;

Method 4: Direct installation of flange;

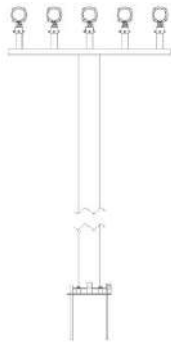

Method 1

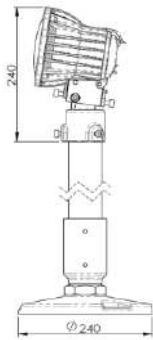

Method 2

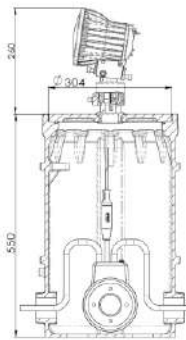

Method 3

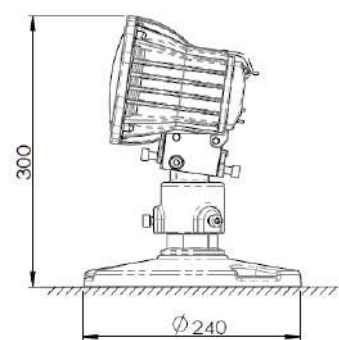

Method 4



- When unpacking, please note whether the carton is intact.
- ※ Damage to the carton may damage the lighting fixture components.



- The wrench must be placed in the hexagonal plane under V-shaped tank of the frangible point for applying force.
- ※ The frangible pole may be damaged or broken.



- Making sure to check whether the cable receptacle contact and waterproof function are good.
- ※ May cause failure of the lighting fixtures.



- During wiring, the lead shall not be pressed by the lighting fixture flange.
- ※ It may cause water entry into the lighting fixtures or other faults of the lighting fixtures.



### 3.5 Installation Steps

#### Installation method 1: Mast installation

- Connect the A6 plug of the lighting fixtures with the secondary receptacle of the isolation transformer and cover the lighting fixture onto the support reserved by the mast.
- Lock the lighting fixtures after adjusting their horizontal and vertical beam angles according to Section 3.6.

#### Installation method 2: Installation of extension pole

- Clean the site, especially the contact with the lighting fixture flange.
- Connect the 2 inches socket frangible part with the lighting fixture flange 240 and screw them.
- Put the Ø60 extension pole into the 2 inches socket frangible part and lock it.
- Connect the A6 plug of the lighting fixtures with the secondary receptacle of the isolation transformer and cover the lighting fixtures on the Ø60 extension pole.
- Lock the lighting fixtures after adjusting their horizontal and vertical beam angles according to Section 3.6.

#### Installation method 3: Installation of L-867 light box

- Screw the 2 inches frangible pole into the deep bucket cover plate and tighten it.
- Connect the A6 plug of the lighting fixtures with the secondary receptacle of the isolation transformer and cover the lighting fixtures on the 2 inches frangible pole.
- Lock the lighting fixtures after adjusting their horizontal and vertical beam angles according to Section 3.6.

#### Installation method 4: Direct floor installation

- Clean the site, especially the place contacting the lighting fixture flange;
- Screw N\*L expansion screw;
- Connect the lighting fixture flange 240 with the ground.
- Load the 2 inches frangible pole into the flange 240 and clamp the lower hexagonal plane for screwing and fixation.
- Lock the lighting fixtures after adjusting their horizontal and vertical beam angles according to Section 3.6.

### 3.6 Adjustment of Horizontal and Vertical Beam Angles of Lighting Fixtures

Before formal use, the horizontal beam angle of the light head must be adjusted. Except that the horizontal angle shall be strictly parallel to the runway centerline, the vertical angle shall strictly comply with the design installation angle. The angle of this system may be adjusted by using the special angle corrector (digital inclinometer).

#### 3.6.1 Operating parts for adjusting lighting fixtures

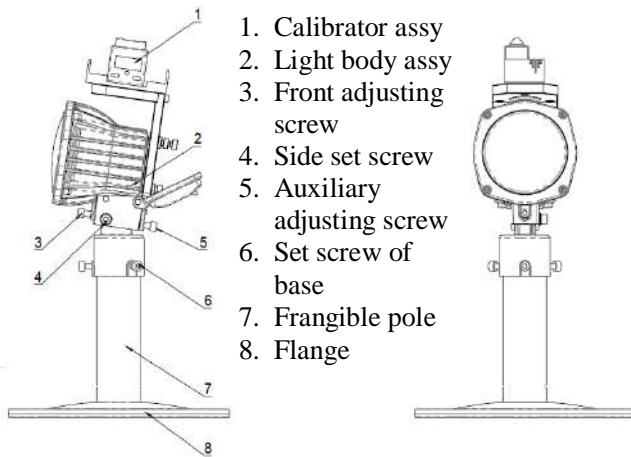

1. Calibrator assy
2. Light body assy
3. Front adjusting screw
4. Side set screw
5. Auxiliary adjusting screw
6. Set screw of base
7. Frangible pole
8. Flange

#### 3.6.2 Corrector operating parts as shown in Figure

1. Inclinometer
2. Inclinometer holder
3. Support plate
4. Lock screw

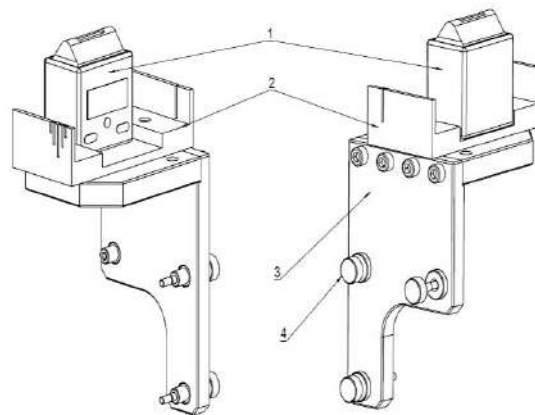

### 3.6.3 Corrector installation

As shown in Figure, open the rear cover of the light body assy, three cylindrical bosses of the calibrator are aligned with those of the light body and screw the set screws (4) to complete the connection between the calibrator and light body assy.

### 3.6.4 Adjustment of horizontal beam angle:

Gently unscrew three socket locking screws on the lighting fixture assy base, through rotating the lighting fixtures to left and right, overlap the horizontal groove of the calibration bracket with the reference marking pole and lock the base locking screws to complete the adjustment of the horizontal beam angle.

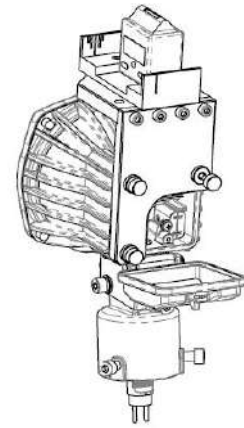

The angles corresponding to the front and rear grooves are shown in Figure below.

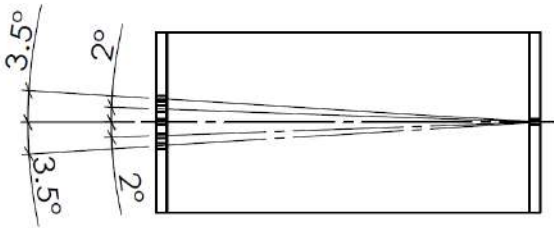

### 3.6.5 Adjustment of vertical beam angle:

Prior to calibration, the level angle of the inclinometer shall be calibrated to 0° on the level slab.

Put the digital inclinometer on the calibration bracket, slightly unscrew the front, rear and side adjusting screws of the lighting fixtures, through adjusting the front and rear adjusting screws, make the lighting fixtures rotate along with the hinged shaft of the light body, observe the value on the digital inclinometer to make it reach the design angle and lock the front, rear and side adjusting screws to complete the adjustment of the vertical beam angle.



- The horizontal adjustment of the lighting fixtures is an important part for their installation, which shall not be omitted.
- ※ The lighting fixture which is not adjusted horizontally may impact the overall light allocation effects of the taxiway.



- Please use the horizontal corrector designated by the manufacturer.
- ※ It may impact the horizontal adjustment effects of the lighting fixtures.

## 4.0 Replacement of Components of Lighting Fixtures

When any damage or failure occurs to any consumable or other component of the lighting fixtures, it is required to timely dismantle the lighting fixtures for replacement of the component. Replacement of components needs to dismount the lighting fixtures, so any minor error will cause adverse consequences. The manufacturer requires users to attach importance to the following warnings. It is required to be careful during disassembly, to conduct comprehensive inspection of lighting fixtures, to replace some vulnerable parts as required, conduct the air seal test and to ensure the performance of the lighting fixtures after disassembly.



- Replacement of components must be conducted by personnel who have received professional training.
- ※ To avoid various failures of the lighting fixtures.



- It is suggested that maintenance of the lighting fixtures be carried out in lighting station or workshop.
- ※ Any impurities mixed in the lighting fixtures may cause failure of the lighting fixtures.



- Do not touch the coating film filter when cleaning the prism surface.
- ※ It may damage the coating film filter or impact the optimal optical performance of the lighting fixtures.



- The manufacturer suggests that various gaskets should be replaced during each maintenance of the lighting fixtures.
- ※ Aging and damage of gaskets are the main reasons for the leakage of lighting fixtures.

## 4.1 Replace Lamp

Take out the lamp: Open the rear cover on the light body assy and pull down the lamp pin. Hold the lamp tail with the thumb and index finger, move the semicircle groove at the lower part of the lamp base backwards out of the lamp holder by gently raising it upwards to take out the lamp.

Install the lamp: Hold the lamp tail with the thumb and index finger, the rectangular groove on the upper part of the light base is aligned with the lower part of the jump ring, place the semicircle groove at the lower part of the lamp base into the corresponding positioning boss of the lamp holder by gently raising it upwards and insert the lamp pin into the fixed base.

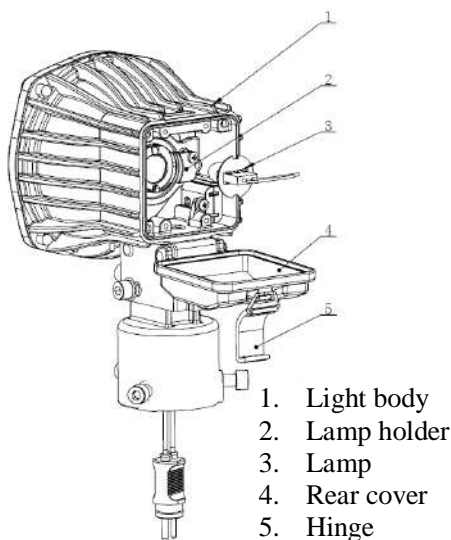

- The manufacturer suggests that the lighting fixtures should be systematically replaced when the service life of the LED lamp reaches 80%.
- ※ To ensure the consistency of light intensity of whole circuit.



- When a lamp is installed, the cloth gloves shall be worn.
- ※ Oil on the hand contaminating the lamp glass may cause crack of the lamp.

## 5.0 Operation and Control

The lighting fixtures are applicable to CCR power supply 6.6A circuit special for airports, which forms a secondary circuit with the lighting fixtures through secondary lead of isolation transformer connected on primary circuit. Due to the use of isolation transformer, the damage of lamp of single lighting fixture will not affect whole series circuit.

### 5.1 Light Wiring Schematic Diagram

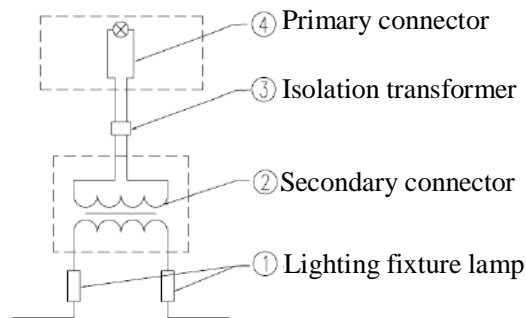

Wiring Diagram

### 5.2 Light Intensity Adjustment and Control

In actual use, according to weather visibility, light intensity of the lighting fixtures may be adjusted through different current output by CCR, and varies significantly.

If it is used on occasion of lower than rated current (6.6A), it may greatly improve the service life of lamp.

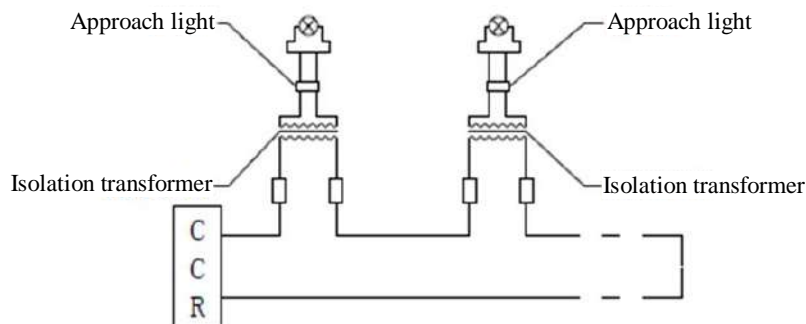

Return Circuit Wiring Diagram



- Using power supply other than CCR is strictly prohibited.
- ※ Other power supply may cause damage to light source or other assy of the lighting fixtures, or even malfunctions of power supply.

## 6.0 Maintenance of Lighting Fixtures

Suggestions for daily maintenance provided in this section are only for reference. Airports may formulate their own daily maintenance guidelines with reference to other provisions or maintenance experience of airport staff; the manufacturer does not provide any hard-and-fast rules.

Maintenance of the lighting fixtures for airports shall be conducted by professionals as stated in 1.0 Foreword.

### 6.1 Daily Maintenance

Interval	Check	Activity
Every day	No light output or flashing	Replace the lamp
	Light output is lower	<ol style="list-style-type: none"> <li>1. Clean the Optical cover surface if it is dirty.</li> <li>2. Check deviation or moisture of the lighting fixtures.</li> <li>3. Check aging or displacement of LED.</li> </ol>
Every week	Obstacles to light output channel	Clean the path and Optical cover surface.
Every month	Existence of moisture and water (Visual check of internal surface of Optical cover)	<ol style="list-style-type: none"> <li>1. Open the body.</li> <li>2. Clean, dry and check.</li> <li>3. Replace the gasket of the light body and other parts damaged.</li> </ol>
Every two months	Tighten the screws	<p>Check whether screw for tightening light body is locked.</p> <p>Use the tools such as wrench and sealant by referring to the Table in Section 3.4.</p>
Every half a year	Water in the base	<ol style="list-style-type: none"> <li>1. Pump out the water in the base.</li> <li>2. Move and dismantle it and observe the damage to the lighting fixtures by water.</li> <li>3. Dispose of the water inlet.</li> </ol>
After snow removal	Damage to lighting fixtures	<ol style="list-style-type: none"> <li>1. Replace seriously damaged light.</li> </ol>
After snow removal	Light output is lower	<ol style="list-style-type: none"> <li>1. Remove the snow on the optical cover with a powerful sweeper.</li> <li>2. Clean the Optical cover surface if it is dirty.</li> <li>3. Check deviation or moisture of the lighting fixtures.</li> <li>4. Check the lamp aging or displacement.</li> </ol>





- The manufacturer suggests that times of daily maintenance should be increased in rainy season.
- ※ To ensure normal operation of lighting fixtures.



- Live line maintenance of the lighting fixtures is strictly prohibited; in case of lightning and/or thunderstorm, maintenance of the lighting fixtures is prohibited.
- ※ It may cause electric shock accident.



- The lighting fixture cover shall not be taken down on site without authorization.
- ※ It may cause fault of the lighting fixtures.



- Only professional operator is allowed to dismount and assemble the lighting fixtures.
- ※ It may cause fault of the lighting fixtures.



- Unless the frangible pole is replaced, do not dismount the assys of the extension pole and frangible pole.
- ※ It may damage the frangible pole.



- It is necessary to use torque wrench. Power wrench is strictly prohibited.
- ※ Otherwise, it may damage screw and thread, and thus cause an accident.

## 6.2 Regular Spot Check and Troubleshooting

Serial No.	Failure Phenomenon	Possible Reasons	Countermeasures
1	No light output	The lamp is damaged.	Replace the lamp.
2	The lighting fixtures is darker	The Optical cover surface is dirty.	Clean the Optical cover surface.
3	Existence of moisture and water	Damage to the Optical cover or gasket	Replace the Optical cover or gasket.

## 7.0 List of Components and Ordering of Spare Parts and Accessories

The list of parts of this product and relevant ordering information of the spare parts and accessories are shown in the Table of this Chapter. The manufacturer accepts to order in a manner of component or separate ordering of the parts. When ordering, please contact the manufacturer or deal according to the ordering No. listed in the Table. The manufacturer recommends to purchase some key parts from the original manufacturer to ensures all indexes of the lighting fixtures.

### List of components and spare articles:

Structure No.	Component Name	Order No.	Remarks
1	Front Cover	45515	Front cover bracket
2	Optical cover	31108	Front glass JJD
3	Optical cover gasket	41110	Adhesive tape JJD sealing component of front cover
4	Filter	31317-G	Filter (coating film) 115-green
		31317-R	Filter (coating film) 115-red
5	Reflector	31109	Glass reflector
6	Light body	2451	Uni-directional light body
7	Fixed holder of lamp	45518	Lamp holder of elevated lighting fixtures- lamp holder PK30D (assy)
8	Lamp	L64361	Prefocus halogen light plate 150W .6A
		L64341	Prefocus halogen light plate 100W 6.6A
		L64319	Prefocus halogen light plate 45W 6.6A
9	Light body gasket	41111	Rear cover gasket- sealing component
10	Rear Cover	45516	Rear Cover JJD
11	Hinge pin of rear cover	45522	Hinge pin- hinge pin of rear cover III
12	Front adjusting screw	GB/T70.1-2000	Hexagon socket head cap screw M8×35
13	Check ring	GB/T896-1986	Opening check ring 4-flat washer
14	Hinged shaft of light body	45523	Pin roll-hinged shaft of light body
15	Rear adjusting screw	GB/T70.1-2000	Hexagon socket head cap screw M8×30
16	Side locking screw	GB/T70.1-2000	Hexagon socket head cap screw M8×16
17	Body gasket	44517	Gasket JJD
18	Set screw	GB/T70.1-2000	Hexagon socket head cap screw M8×16
19	Fixed base of terminal block	41221	Lighting fixture receptacle
20	Waterproof gland	48404	Metal waterproof gland MG18×1.5
21	Plug	70603	Secondary cable connector-A6 twin-core plug (flat)- high temperature

**List of supporting accessories of this product is as follows (needing additional order):**

Serial No.	Order No.	Description
1	276A1	Flange 240mm
2	27683	Flange 304mm (FAA standard)
3	924252	2 inches sleeve frangible assy
4	924241	2 inches frangible pole
5	ITF-045-066	Isolation transformer 45W
6	ITF-100-066	Isolation transformer 100W
7	ITF-150-066	Isolation transformer 150W
8	70703	Secondary receptacle A7
9	954211	Corrector assy
10	TJB-12	Isolated transformer box



- Spare parts shall be purchased from us.
- ※ Parts of other brands may impact the performance of the lighting fixtures.



- Please tell us the order No. when purchasing the spare parts.
- ※ Otherwise they are unfavorable for the factory management, causing incorrect delivery.

## **8.0 Packaging, Transportation and Storage**

### **8.1 Packaging and Weight**

Packaging: 1 pc / box (excluding flange)

Gross weight: 2.33 KG / box

Volume: 220\*220\*265

Flange (Ø240) 6 pcs / box

Gross weight: 8.5 KG / box

Volume: 250\*250\*185

### **8.2 Transportation Mode**

Well packed products may be transported in three modes- railway, highway and air according to factors such as transportation distance, quantity of lights and delivery cycle.

### **8.3 Storage**

This product shall be stored in a place which is dry, well ventilated and far away from heat source and has no caustic gas. Custody should be checked on a regular basis.

The final right to interpret this manual is reserved by Airsafe Airport Equipment Co., Ltd.

Thanks for your purchasing and using AIRSAFE product!

Address: No. 38, Anxin Road, Xuhang Town, Jiading  
District, Shanghai, China

Postal Code: 201800

Tel.: 021-53540453

Fax: 021-63643114

E-mail: [sales@airsafe.com.cn](mailto:sales@airsafe.com.cn)