

LED Elevated Uni-directional Lighting Fixtures

**Elevated Approach Centerline Light and Cross Bar Light, Elevated Approach Side-row Light,
Elevated Runway Threshold Light, Elevated Runway Threshold Wing Bar Light, Elevated
Runway End Light and Elevated Stop Bar
EUL-AP-LED, EUL-SR-LED, EUL-TH-LED,
EUL-THW-LED, EUL-ED-LED and EUL-SB-LED**

Operation Manual



Please read this manual carefully before construction, installation and operation of the product.
Please keep this manual properly for further reference.

This manual is subject to change without prior notice.

Airsafe Airport Equipment Co., Ltd.

Revision Description

No.	Description	Version No.	Revised by	Approved by	Date
1	First release	V1.0	Z.H	C.SY	Aug. 12, 2016

Table of Content

1.0 Foreword.....	- 1 -
1.1 Illustrations and Meanings	- 2 -
1.2 Safety Rules and Notices	- 3 -
1.3 Quality Assurance and Responsibility	- 4 -
2.0 Introduction to Lighting fixtures	- 5 -
2.1 Technical Specifications	- 8 -
2.2 Application Environment	- 8 -
2.3 Application Scope.....	- 9 -
2.4 Technical Parameters	- 9 -
2.5 Technical Features	- 10 -
2.6 Structure.....	- 11 -
2.7 Fault Detection or Lamp Bypass Functions	- 12 -
3.0 Installation	- 13 -
3.1 Installation Methods	- 13 -
3.2 Installation Tools	- 14 -
3.3 Screw and Torsion	- 14 -
3.4 Installation of Lighting Fixtures.....	- 15 -
3.5 Adjustment of Horizontal and Vertical Beam Angle of Lighting Fixtures	- 17 -
4.0 Replacement of Components of Lighting Fixtures	- 19 -
4.1 How to Replace Optical Cover	- 20 -
4.2 How to Replace Optical Cover Gasket.....	- 20 -
5.0 Operation and Control.....	- 21 -
5.1 Light Wiring Schematic Diagram	- 21 -
5.2 Light Intensity Adjustment and Control	- 21 -
6.0 Maintenance of Lighting Fixtures	- 22 -
6.1 Daily Maintenance	- 22 -
6.2 Regular Spot Check and Troubleshooting	- 23 -
7.0 List of Components and Ordering of Spare Articles and Accessories	- 24 -
8.0 Packaging, Transportation and Storage	- 26 -
8.1 Packaging and Weight	- 26 -
8.2 Transportation Mode	- 26 -
8.3 Storage	- 26 -

1.0 Foreword

ICAO *Airport Service Manual* Part 9 “Airport Maintenance Practices” and FAA AC150/5345-26 *Maintenance of Airport Visual Aid Facilities* are the highest criteria for site installation and maintenance of such lighting fixtures. This manual was compiled with considerable reference to these two criteria.

The content stated in this manual is absolutely important, so construction personnel must read it carefully before construction. After properly understanding the entire content of this manual, construction personnel should carry out the construction in strict accordance with the methods specified herein, to ensure that the product is safely and properly installed in place.

Routine airport maintenance personnel should carry out the routine maintenance in strict accordance with the methods specified by relevant provisions, to ensure that the lighting fixtures are in the best operation condition.

Related personnel must strictly follow safety criteria. Any personnel without specialized training is strictly forbidden to touch the lighting fixtures and devices. Live line work should be avoided under any circumstances. Construction or maintenance personnel should get acquainted with first-aid knowledge, in case of any unexpected events.

1.1 Illustrations and Meanings

- Following illustrations will appear in this manual where necessary to remind or warn construction or maintenance personnel.
- Please continue reading the subsequent content of this manual after properly understanding the meanings of these illustrations.



- To remind that the behavior may cause serious injury or death.
- ※ Detailed description will be given in the box.



- To remind that the behavior may cause injury to people or damage to product.
- ※ Detailed description will be given in the box.



- To notify that the behavior is prohibited.
- ※ Detailed description will be given in the box.

1.2 Safety Rules and Notices



- Using the light fixtures outside of airport is strictly prohibited.
- ※ Inadequate maintenance or casual touch will cause light faults.



- Using power supply other than CCR is strictly prohibited.
- ※ It may damage the lighting fixtures and even cause fault of the power supply.



- The frangible pole is equipped at the lower part of the light pole. When it is installed, upper part of the frangible pole bearing the force is prohibited.
- ※ The frangible pole may be broken.



- Making sure that CCR is on power-off state before the installation or maintenance of the lighting fixtures.
- ※ Current surge produced during the installation of the lighting fixtures may cause damage to light source.



- Non-professional electricians are strictly forbidden to maintain any electrical fault of the lighting fixtures.
- ※ It may damage any electrical component of the lighting fixtures or cause bigger fault.



- Be careful when handling the lighting fixtures.
- ※ Drop or collision may damage the parts or cause personal injury.



- Replace the lead immediately in case the jacket of second cable is damaged.
- ※ It may cause short circuit, electric shock or other failure.



- Don't touch the damaged optical cover or other glass directly with hands.
- ※ Glass fragments may scratch hands.



- Touching the lighting fixtures with wet hand is strictly prohibited.
- ※ It may cause electric shock or other accident.

1.3 Quality Assurance and Responsibility

Any defect in design, material or workmanship, which may occur during proper and normal use over a period of one year from date of installation but less than 15 months from date of shipment, or within the warranty period of the tender, will be repaired or replaced by manufacturer free of charge. The warranty doesn't cover the failures resulting from lamp burnt out, improper maintenance, installation or operation, or damages due to snow ploughs. Manufacturer shall not be liable to any further claims or particularly claims for damages not affecting the goods themselves.

2.0 Introduction to Lighting fixtures

This manual involves the following series lighting fixtures:

EUL-AP-LED-----Elevated Approach Centerline Light and Cross Bar
Light

EUL-SR-LED-----Elevated Approach Side-row Light

EUL-TH-LED-----Elevated Runway Threshold Light

EUL-THW-LED-----Elevated Threshold Wing Bar Light

EUL-ED-LED-----Elevated Runway End Light

EUL-SB-LED-----Elevated Stop bar

Type of LED Approach Centerline Light and Cross Bar Light (EUL-AP-LED):

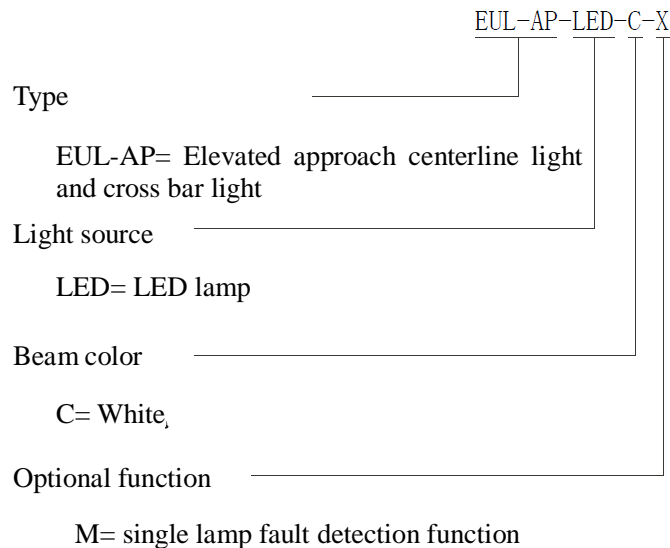

Type of LED Elevated Approach Side-row Light (EUL-SR-LED):

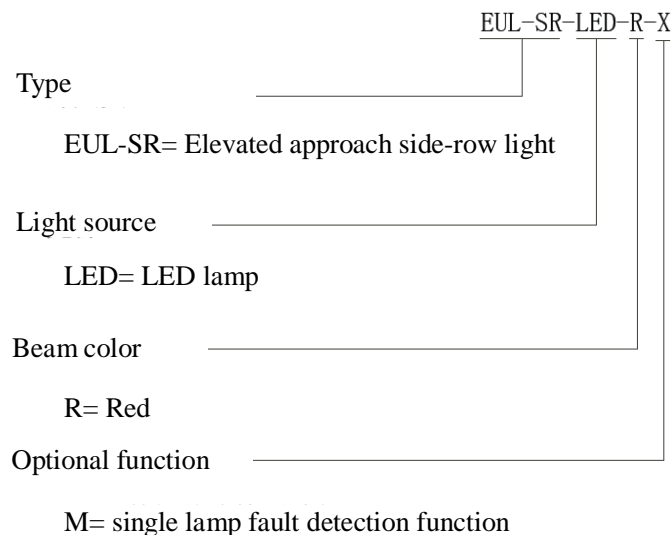

Type of LED Elevated Runway Threshold Light (EUL-TH-LED):

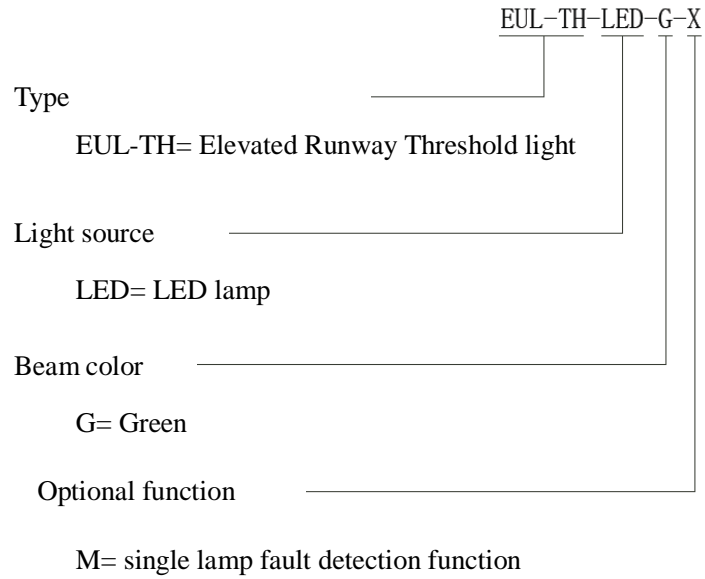

Type of LED Elevated Runway Threshold Wing Bar Light (EUL-THW-LED):

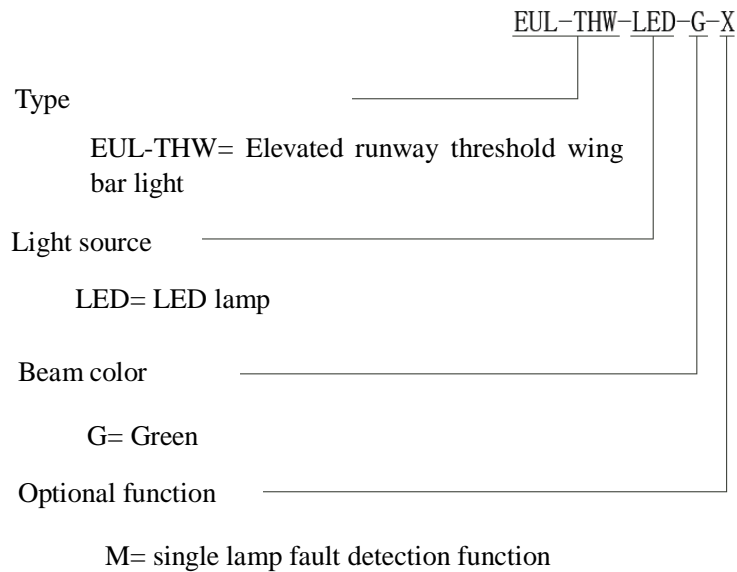

Type of LED Elevated Runway End light (EUL-ED-LED):

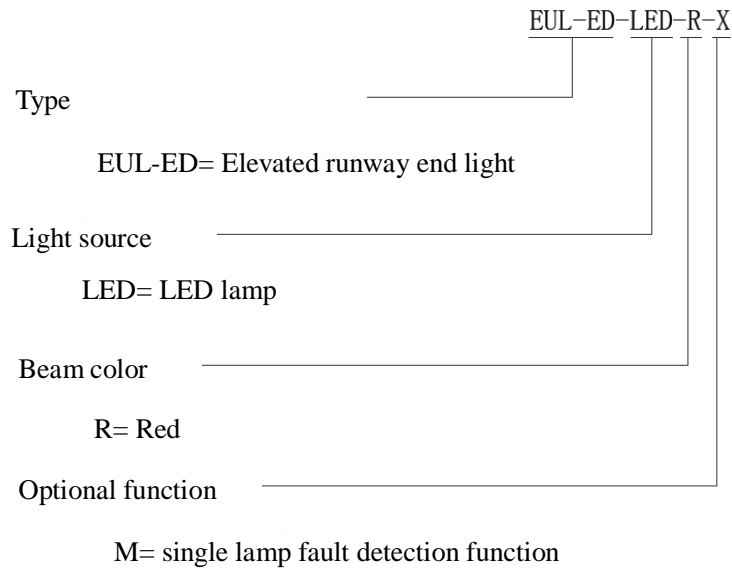

Type of LED Elevated Stop Bar (EUL-SB-LED):

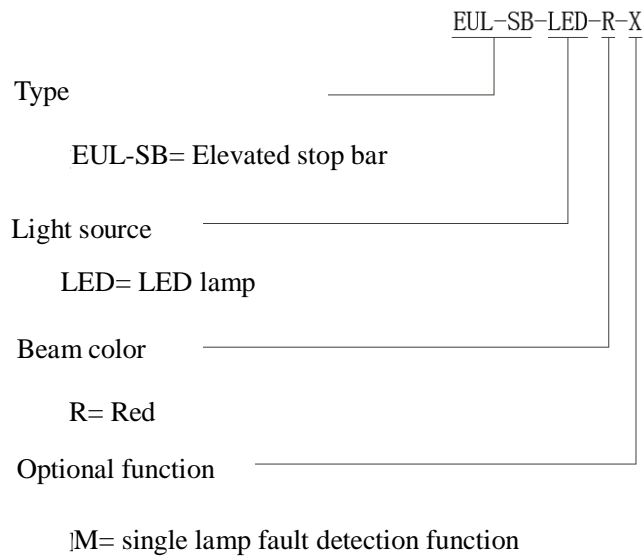

2.1 Technical Specifications

This product conforms to the provisions of the following standards or technical specifications. For dated standards or technical specifications, only the edition cited applies. For undated references, the latest edition of the referenced document (including any amendments) applies.

- International Electrotechnical Commission (IEC) TS 61827;
- Convention on International Civil Aviation Annex 14- *Aerodromes* Volume 1;
- International Civil Aviation Organization (ICAO)- *Aerodrome Design Manual*- Part 4: Visual Aids;
- Federal Aviation Administration (FAA) AC150/5345-46;
- Federal Aviation Administration (FAA) EB 67;
- GB/T 7256 *General Requirements of Lighting Fixtures for Civil Airport*;
- Department of Airport of Civil Aviation Administration of China: Advisory Circular, *Technical Requirements for Runway and Taxiway Aid Lighting Fixtures* (AC-137-CA-2015-03);
- Department of Airport of Civil Aviation Administration of China, Advisory Circular, *General Technical Requirements for Civil Airport LED Aid Lighting Fixtures* (AC-137-CA-2015-01).

2.2 Application Environment

- Altitude: below 4,000m;
- Outdoor: -55°C ~ +55°C;
- Relative air humidity: not more than 95%;
- In rain, snow, ice and water;
- Expose to corrosive salt atmosphere.
- Basic earthquake intensity VII.

2.3 Application Scope

Elevated approach centerline light and cross bar light, elevated approach side-row light, elevated runway threshold light, elevated runway threshold wing bar light, elevated runway end light and elevated stop bar for Category I, II and III airports.



- Using the lighting fixtures beyond the specified scope is strictly prohibited.
- ※ Application beyond the specified scope will cause damage or risk to any component.

2.4 Technical Parameters

Description	Type	Rated Power	Power Factor	Life of Light Source
Elevated Approach Centerline Light and Cross Bar Light	EUL-AP-LED-C-X	36VA	≥ 0.9	$\geq 50,000\text{h}$
Elevated Approach Side-row Light	EUL-SR-LED-R-X	28VA	≥ 0.9	$\geq 50,000\text{h}$
Elevated Runway Threshold Light	EUL-TH-LED-G-X	36VA	≥ 0.9	$\geq 50,000\text{h}$
Elevated Runway Threshold Wing Bar Light	EUL-THW-LED-G-X	36VA	≥ 0.9	$\geq 50,000\text{h}$
Elevated Runway End Light	EUL-ED-LED-R-X	14VA	≥ 0.9	$\geq 50,000\text{h}$
Elevated Stop Bar	EUL-SB-LED-R-X	10VA	≥ 0.9	$\geq 50,000\text{h}$

2.5 Technical Features

- Long life, energy saving, maintenance free and other characteristics of LED will bring huge economic benefits to customers;
- With the proprietary optical design, the lighting fixtures still have the all-optical output when the front glass is covered in part;
- Strict LED color management ensures the consistency of light color;
- Dimming curve of the lighting fixtures is consistent with the change of halogen lamp, and meets the requirements of FAA;
- Proprietary drive circuit and thermal management solution greatly improve the reliability and service life of the lighting fixtures;
- Power factor is greater than 0.9, which minimizes the grid interference;
- Optional single lamp fault detection function enables the light to be open as halogen lamp once LED fails;
- Compact structure, attractive appearance, small windward area and strong wind resistance capability;
- Main body of the lighting fixtures is made of aluminum alloy material with special anodizing surface treatment, and all fasteners are made of stainless steel, thus being applicable to all kinds of harsh environment;
- High precision components machining ensures dimensional quality and precision of the lighting fixtures;
- Forged frangible device with precise machining, complying with FAA standards and ensuring stable and reliable performance;
- The overall IP rating of the lighting fixtures reaches IP65, and it is difficult for the dust to be deposited in them;
- The lighting fixtures can be connected to 1 inches or 2 inches frangible tube, which ensures convenient and secure installation;
- The corrector may be directly installed for the light body and the installation and calibration are convenient and accurate;
- The components are of modularized design for common use, which are applicable to various LED uni-directional elevated lighting fixtures, effectively reducing the spare parts inventory;

2.6 Structure

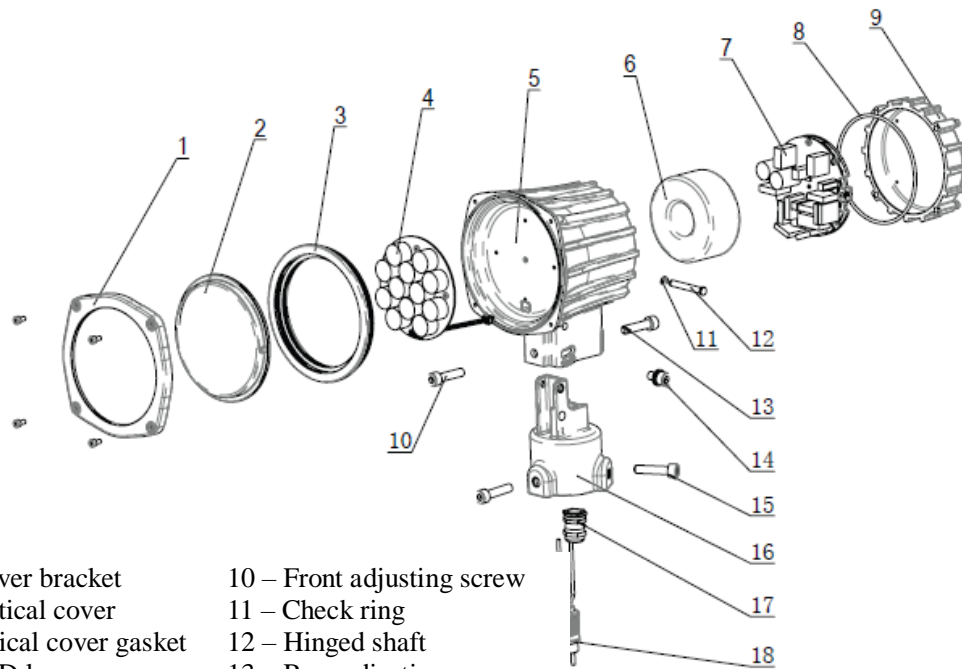

- | | |
|--------------------------|----------------------------|
| 1 – Cover bracket | 10 – Front adjusting screw |
| 2 – Optical cover | 11 – Check ring |
| 3 – Optical cover gasket | 12 – Hinged shaft |
| 4 – LED lamp | 13 – Rear adjusting screw |
| 5 – Light body | 14 – Side locking screw |
| 6 – Transformer | 15 – Set screw |
| 7 – Drive assy | 16 – Body base |
| 8 – Body gasket | 17 – Waterproof gland |
| 9 – Rear cover | 18 – Plug |

2.7 Fault Detection or Lamp Bypass Functions

This product complies with the requirements of FAA EB67 and GB/T 7256, and integrates single lamp fault detection function; Or, it can provide the option of lamp bypass function in accordance with the requirements of FAA AC150-5345/46.

Single lamp fault detection function: The light will take automatic action to cut off the input when any malfunction occurs on the lamp and achieve an effect similar as the open circuit of ordinary halogen light once it is burnt. This function is generally used in conjunction with single lamp controller, to help single lamp control and monitoring system to identify any failed light. And it is integrated into the interior of the lighting fixtures, without need of any external device. Please specify this function during the ordering if needed.

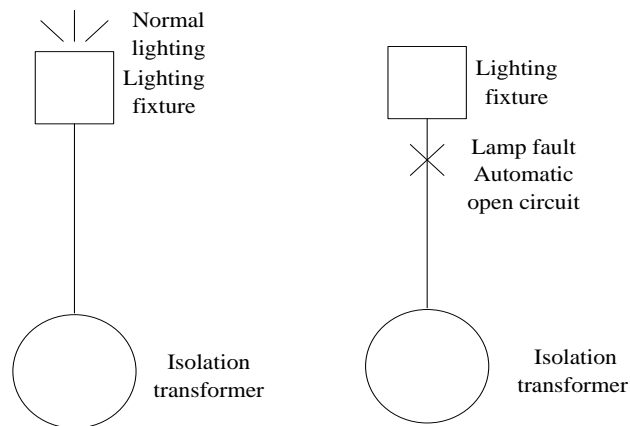

Lamp bypass function: After any failure occurs to the lamp, relatively, the input terminal of light will be short to the isolation transformer. This function is generally applicable to occasions that one isolation transformer carries multiple lighting fixtures. If one or more of these lighting fixtures is or are damaged, the remaining lighting fixtures will not go out thereby. This function is integrated into the interior of the lighting fixtures, without need of any external device. Please specify this function during the ordering if needed.

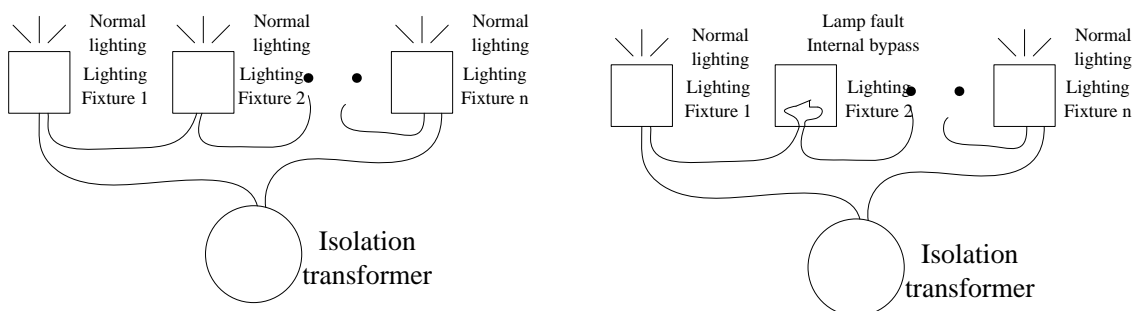

3.0 Installation

Requirements for installation should be learned thoroughly before installation including installation tools and site requirement, etc., to avoid malfunction of the light due to incorrect installation.

3.1 Installation Methods

Method 1: Mast installation;

Method 2: Ground installation of extension pole;

Method 3: L-867 deep bucket flange installation;

Method 4: Direct ground installation;

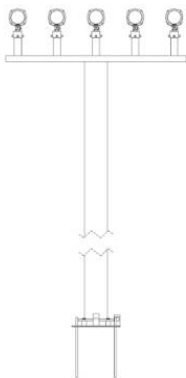

Method 1

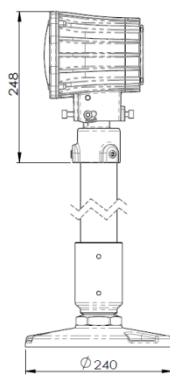

Method 2

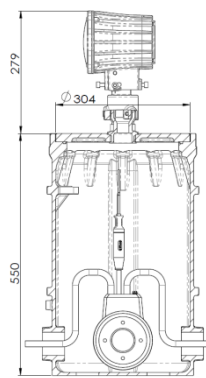

Method 3

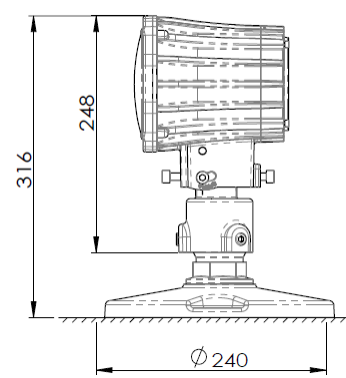

Method 4



- It is suggested to use the brick to cushion the isolation transformer and circuit control box.
- ※ The deep bucket dropping into the water accidentally is prohibited to avoid the isolation transformer being soaked in the water.

3.2 Installation Tools

Choosing right tools not only can ensure the correct and reliable installation of the lighting fixtures, but also can reduce unnecessary safety accidents. *Special Tools* listed in the table may be purchased from the manufacturer or any distributor. Universal tools are available on local hardware market. Please pay attention to measurement range during procurement.

- Special tool- Elevated light nut wrench: be used to dismount the lighting fixtures, and available directly from the manufacturer or any distributor.
- Universal tool- Torque screwdriver: be used to dismount screw, equipped with PH2 cross screwdriver, and sellable in various hardware stores.

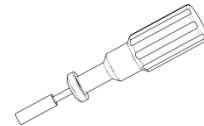

Recommended range is 1-6N.m

3.3 Screw and Torsion

The torque listed in this section is only for reference by maintenance personnel. Correct fastening force of screw can ensure normal operation of the lighting fixtures. If screw is too tight, it will easily damage the lighting fixtures; on the contrary, if screw is easy to fly out, it may cause an accident.

Serial No.	Screw Type	Tool	Torque
1	M8 screw	Internal hexagonal wrench	5 N·m
2	M4 screw	Internal hexagonal wrench	1.5 N·m



- Please use torque wrench or other special tool for installation.
- ※ Informal tools may cause damage to fasteners or personal injury.

3.4 Installation of Lighting Fixtures

- This Operation Manual does not define the installation of the flange. For the technical support, please contact the construction party and the dimension of the chassis installed, please see Figure below:

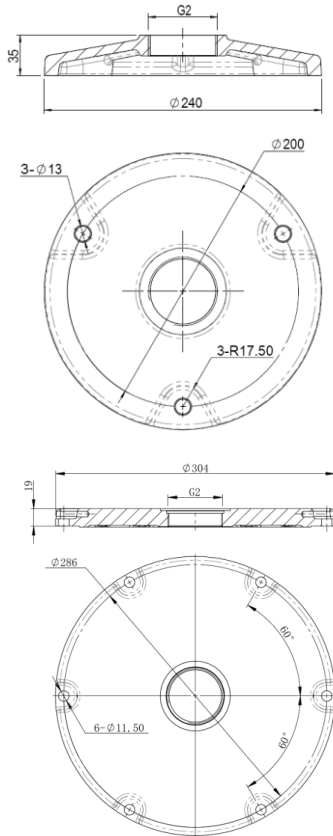

- Installation of optional parts:

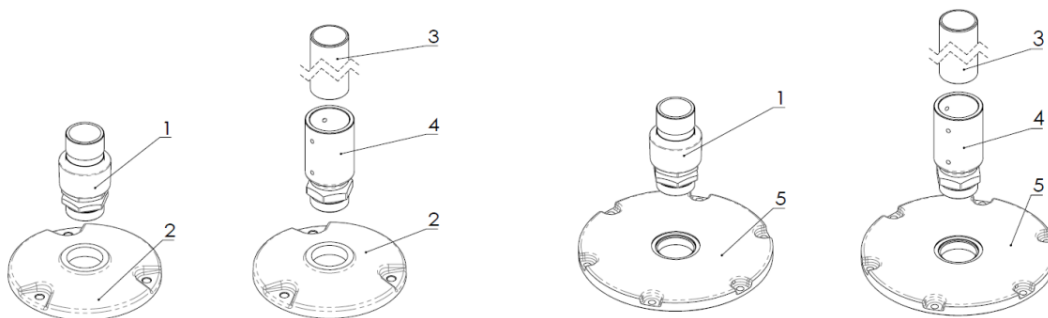

- | | | |
|----------------------------|-----------------------------------|---------------|
| 1. 2 inches frangible part | 3. Ø60 extension pole | 5. Flange 304 |
| 2. Flange 240 | 4. 2 inches socket frangible part | |

Installation method 1: Mast installation

- When unpacking the package, check whether the parts are complete. Carefully handle the lighting fixtures to void damaging the assy.
- Connect the A6 plug of the lighting fixtures with the secondary receptacle of the isolation

transformer and cover the lighting fixture onto the support reserved by the mast.

- Lock the lighting fixtures after adjusting their horizontal and vertical beam angles according to Section 3.6.

Installation method 2: Installation of extension pole

- Clean the site, especially the contact with the lighting fixture flange.
- Connect the 2 inches socket frangible part with the lighting fixture flange 240 and screw them.
- Put the Ø60 extension pole into the 2 inches socket frangible part and lock it.
- Connect the A6 plug of the lighting fixtures with the secondary receptacle of the isolation transformer and cover the lighting fixtures on the Ø60 extension pole.
- Lock the lighting fixtures after adjusting their horizontal and vertical beam angles according to Section 3.6.

Installation method 3: Deep bucket installation

- Screw the 2 inches frangible part into the deep bucket cover plate and tighten it.
- Connect the A6 plug of the lighting fixtures with the secondary receptacle of the isolation transformer and cover the lighting fixtures on the 2 inches frangible part.
- Lock the lighting fixtures after adjusting their horizontal and vertical beam angles according to Section 3.6.

Installation method 4: Flange installation

- Connect the lighting fixture flange 240 with the ground.
- Load the 2 inches frangible part into the flange 240 and clamp the lower hexagonal plane for screwing and fixation.
- Lock the lighting fixtures after adjusting their horizontal and vertical beam angles according to Section 3.6.



- The wrench must be placed in the hexagonal plane under V-shaped tank of the frangible point for applying force.
- ※ The frangible pole may be damaged or broken.



- The non-standard tools shall not be used for assembling and dismantling the lighting fixtures.
- ※ It may cause personal injury or damage to the lighting fixtures.



- During wiring, the lead shall not be pressed by the lighting fixture flange.
- ※ It may cause water entry into the lighting fixtures or other faults of the lighting fixtures.

3.5 Adjustment of Horizontal and Vertical Beam Angles of Lighting

Fixtures

Before formal use, the horizontal beam angle of the light head must be adjusted. Except that the horizontal angle shall be strictly parallel to the runway centerline, the vertical angle shall strictly comply with the design installation angle. The angle of this system may be adjusted by using the special angle corrector (digital inclinometer).

3.5.1 Operating parts for adjusting lighting fixtures

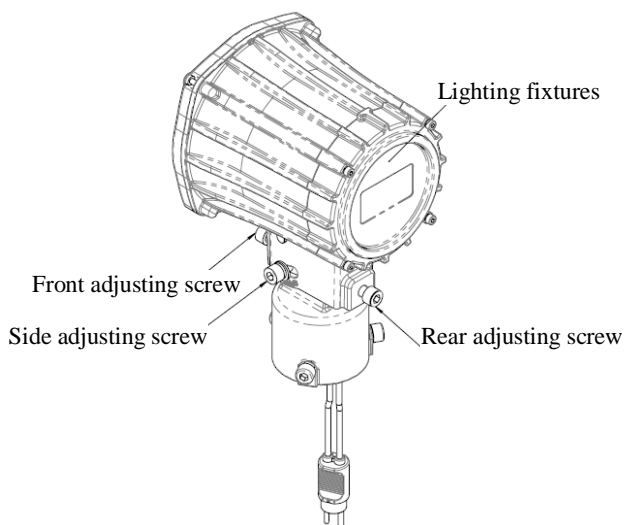

3.5.2 Corrector operating parts as shown in Figure

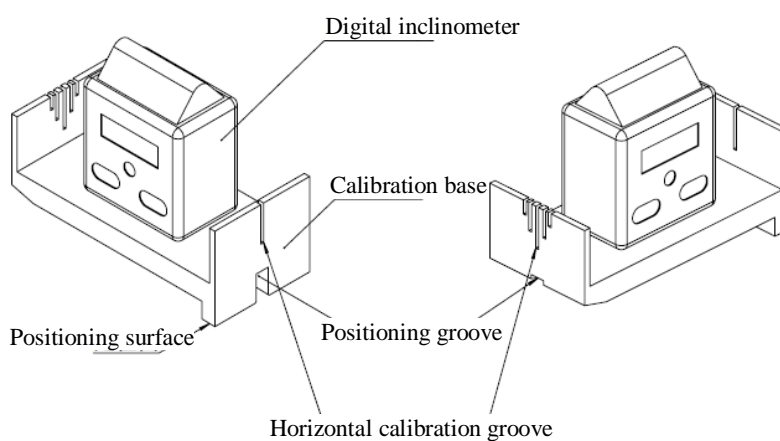

3.5.3 Corrector installation

As shown in Figure, put the corrector on the light body; the positioning groove and surface are bound with the connecting piece on the lighting fixtures and the rear of the corrector is close to the rear cover.

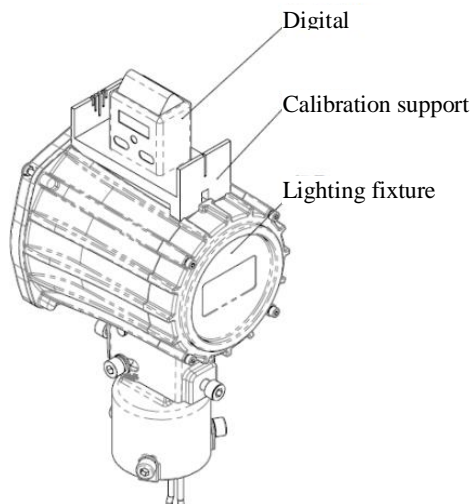

3.5.4 Adjustment of horizontal beam angle:

Gently unscrew three socket locking screws on the lighting fixture assy base, through rotating the lighting fixtures to left and right, overlap the horizontal groove of the calibration bracket with the reference marking pole and lock the base locking screws to complete the adjustment of the horizontal beam angle.

3.5.5 Adjustment of vertical beam angle:

Put the digital inclinometer on the calibration bracket, slightly unscrew the front, rear and side adjusting screws of the lighting fixtures, through adjusting the front and rear adjusting screws, make the lighting fixtures rotate along with the hinged shaft of the light body, observe the value (i.e. angle) on the digital inclinometer to make it reach the design angle and lock the front, rear and side adjusting screws to complete the adjustment of the vertical beam angle.



- The horizontal adjustment of the lighting fixtures is an important part for their installation, which shall not be omitted.
- ※ The lighting fixture which is not adjusted horizontally may impact the overall light allocation effects of the taxiway.



- Please use the horizontal corrector designated by the manufacturer.
- ※ It may impact the horizontal adjustment effects of the lighting fixtures.

4.0 Replacement of Components of Lighting Fixtures

When any damage or failure occurs to any consumable or other component of the lighting fixtures, it is required to timely dismantle the lighting fixtures for replacement of the component. Replacement of components needs to dismantle the lighting fixtures, so any minor error will cause adverse consequences. The manufacturer requires users to attach importance to the following warnings. It is required to be careful during disassembly, to conduct comprehensive inspection of lighting fixtures, to replace some vulnerable parts as required, and to ensure the performance of the lighting fixtures after disassembly.



- Replacement of components must be conducted by personnel who have received professional training.
- ※ To avoid various failures of the lighting fixtures.



- It is suggested that maintenance of the lighting fixtures be carried out in lighting station or workshop.
- ※ Any impurities mixed in the lighting fixtures may cause failure of the lighting fixtures.



- The manufacturer suggests that various gaskets should be replaced during each maintenance of the lighting fixtures.
- ※ Aging and damage of gaskets are the main reasons for the leakage of lighting fixtures.



- The manufacturer recommends to return it to the factory for maintenance.
- ※ The lighting fixture use barrier shall be avoided.

4.1 How to Replace Optical Cover

1. Place the lighting fixture cover upwards (Figure 4-1).
2. Unscrew 4 fixing screws, remove the cover bracket, take out the optical cover out of the cover bracket adhesive tape; replace a new optical cover and ensure that it is closely attached to the adhesive tape (Figure 4-2).
3. Identify the positioning direction of the optical cover and cover bracket and lock 4 screws at opposite angles (Figure 4-3).



Figure 4-1



Figure 4-2



Figure 4-3

4.2 How to Replace Optical Cover Gasket

1. Place the lighting fixture cover upwards (Figure 4-4).
2. Unscrew 4 fixing screws, remove the cover bracket, take out the seal ring of the optical cover; replace a new seal ring of the optical cover and ensure that the adhesive tape is closely attached to the glass (Figure 4-5).
3. Distinguish the positioning direction of the optical cover and cover bracket and lock 4 screws at opposite angles (Figure 4-6).



Figure 4-4



Figure 4-5

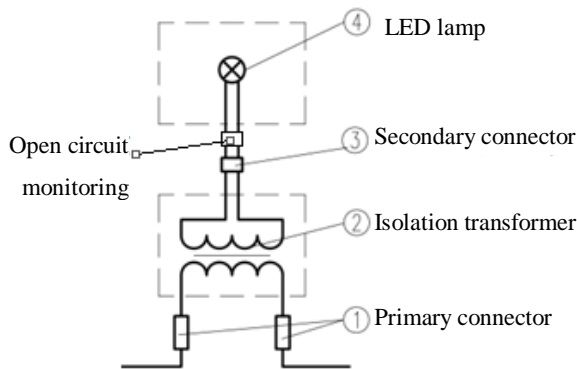

Figure 4-6

5.0 Operation and Control

The lighting fixtures are applicable to CCR power supply 6.6A circuit special for airports, which forms a secondary circuit with the lighting fixtures through secondary outgoing line of isolation transformer connected on primary circuit. Due to the use of isolation transformer, the damage of lamp of single lighting fixture will not affect whole series circuit.

5.1 Light Wiring Schematic Diagram



5.2 Light Intensity Adjustment and Control

During practical use, the light of the lighting fixtures may be adjusted according to the weather visibility and the lighting intensity change of the lighting fixtures complies with the provisions of FAA. When the lighting fixtures are used in the case in which the current is lower than the rated current (6.6A), the service life of the LED will be greatly enhanced.

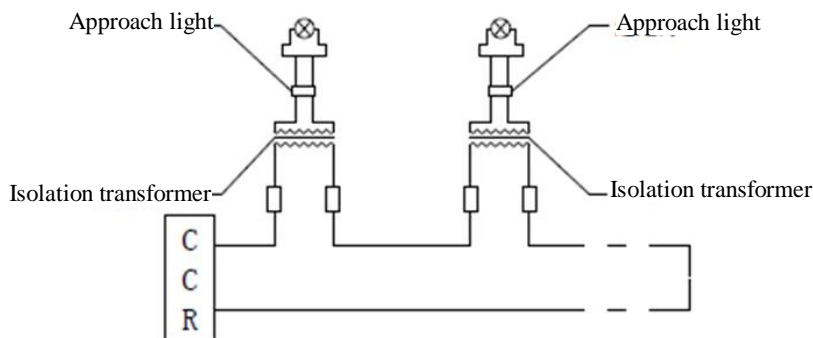

Return Circuit Wiring Diagram



- Using power supply other than CCR is strictly prohibited.
- ※ Other power supply may cause damage to light source or other assy of the lighting fixtures, or even malfunctions of power supply.

6.0 Maintenance of Lighting Fixtures

Suggestions for daily maintenance provided in this section are only for reference. Airports may formulate their own daily maintenance guidelines with reference to other provisions or maintenance experience of airport staff; the manufacturer does not provide any hard-and-fast rules.

Maintenance of the lighting fixtures for airports shall be conducted by professionals as stated in 1.0 Foreword.

6.1 Daily Maintenance

Interval	Check	Activity
Every day	No light output or flashing	Replace LED lamp assy.
	Light output is lower	<ol style="list-style-type: none"> 1. If optical cover surface is dirty, wipe it up. 2. Check deviation or moisture of the lighting fixtures.
Every week	Obstacles to light output channel	Clean surface of route and optical cover.
Every month	Existence of moisture and water (Visual check of internal surface of prism)	<ol style="list-style-type: none"> 1. Open the body. 2. Clean, dry and check. 3. Replace gasket and any other damaged components.
Every two months	Tighten the screws	<p>Check whether screw for tightening light body is locked.</p> <p>Use such tools as wrench and sealant by referring to the Table in Section 3.4.</p>
After snow removal	Damage to lighting fixtures	<ol style="list-style-type: none"> 1. Replace seriously damaged light.
After snow removal	Light output is lower	<ol style="list-style-type: none"> 1. Remove the snow on the optical cover with a powerful sweeper. 2. If optical cover surface is dirty, wipe it up. 3. Check deviation or moisture of the lighting fixtures. 4. Check aging or displacement of LED.
After 50,000h	Replace the lighting fixtures or a sub-return circuit	It is suggested to systematically replace the lighting fixtures when 80% service life is reached.

6.2 Regular Spot Check and Troubleshooting

Serial No.	Failure Phenomenon	Possible Reasons	Countermeasures
1	No light output or flashing	Failure of LED lamp assy or driver	Replace the LED light source assy or driver or return the lighting fixtures to the manufacturer for maintenance.
2	The lighting fixtures are darker	The prism surface is dirty.	Clean the prism surface.
3	Existence of moisture and water	The prism or gasket is damaged.	Replace the prism or gasket.



- The manufacturer suggests that times of daily maintenance should be increased in rainy season.
- ※ To ensure normal operation of lighting fixtures.



- Live lighting fixture maintenance is prohibited and the lighting fixtures shall not be maintained in case of thunder, lightning or rain.
- ※ It may cause electric shock.



- The lighting fixture cover shall not be taken down on site without authorization.
- ※ It may cause fault of the lighting fixtures.



- Only professional operator is allowed to dismount and assemble the lighting fixtures.
- ※ It may cause fault of the lighting fixtures.



- Unless the frangible pole is replaced, do not dismount the assys of the extension pole and frangible pole.
- ※ It may damage the frangible pole.



- Torque wrench other than powerful wrench must be used.
- ※ Otherwise it may damage the screw and thread to result in accidents.

7.0 List of Components and Ordering of Spare Articles and

Accessories

The table in this chapter lists the components and relevant ordering information of the spare articles and accessories of this product. The manufacturer accepts the order in assembly mode and separate order of components. When ordering, please contact the manufacturer or any distributor according to order number listed in the table. The manufacturer suggests that some important components should be purchased from original factory to ensure various indicators of the lighting fixtures.

List of components and spare articles:

Structure No.	Component Name	Order No.	Description
1	Cover bracket	45515	Front cover bracket
2	Optical cover	31108	Front glass
3	Optical cover gasket	41110	Adhesive tape of front cover
4	LED lamp assy	79242-12-C 79242-12-R 79142-12-G 79142-4-R 79142-2-R	LED lamp 103 (12-0) white LED lamp 103 (12-0) red LED lamp 103 (12-0) green LED lamp 103 (4-0) red LED lamp 103 (2-0) red
5	Body	241D1	Light body LED
6	Transformer	79125	Ring transformer (35W)
7	drive assy	979143	Circuit board-approach light- 12X
8	Body gasket	41154	O-gasket 102×3
9	Rear cover	241E1	Rear cover LED
10	Front adjusting screw	GB/T70.1-2000	Hexagon socket head cap screw M8×35
11	Check ring	GB/T896-1986	Opening check ring 4
12	Hinged shaft of light body	45523	Pin roll-hinged shaft of light body
13	Rear adjusting screw	GB/T70.1-2000	Hexagon socket head cap screw M8×35
14	Side locking screw	GB/T70.1-2000	Hexagon socket head cap screw M8×16
15	Set screw	GB/T70.1-2000	Hexagon socket head cap screw M8×16
16	Body gasket	45517	Gasket JJD
17	Waterproof gland	48404	Metal waterproof gland MG18×1.5
18	Plug	HT70603	Secondary cable connector- A6 dual-core plug (Flat)- high temperature

List of supporting accessories of this product is as follows (needing additional order):

Serial No.	Order No.	Description
1	924241	2 inches frangible part
2	276A1	Flange 240mm
3	Ø60 extension pole	It may be customized according to the requirements.
4	924252	2 inches sleeve frangible assy
5	27683	Flange 304mm (FAA standard)
6	70703	Secondary receptacle A7
7	954211	Corrector assy
8	TJB-12-L867	L867 deep bucket
9	ITF-25-066	Isolation transformer 25W
10	ITF-45-066	Isolation transformer 45W



- When optical cover cannot work properly, please order it from our company.
- ※ Other brand glass may affect lighting angle and light intensity of the lighting fixtures.



- If secondary plug is damaged, please order it from our company.
- ※ Other brand plug may cause light leakage and other failures.



- When any frangible article is damaged, please order it from our company.
- ※ Frangible articles are components special for the lighting fixtures, and cannot be replaced.

8.0 Packaging, Transportation and Storage

8.1 Packaging and Weight

Packaging: 1 pcs / box

Gross weight: 4 KG / box

Volume: 220*220*265

8.2 Transportation Mode

Well packed products may be transported in three modes- railway, highway and air according to factors such as transportation distance, quantity of lights and delivery cycle.

8.3 Storage

This product shall be stored in a place which is dry, well ventilated and far away from heat source and has no caustic gas. Custody should be checked on a regular basis.

The final right to interpret this manual is reserved by Airsafe Airport Equipment Co., Ltd.

Thanks for your purchasing and using AIRSAFE product!

Address: No. 38, Anxin Road, Xuhang Town, Jiading
District, Shanghai, China
Postal Code: 201800
Tel.: 021-53540453
Fax: 021-63643114
E-mail: sales@airsafe.com.cn