

12 Inches LED In-pavement Runway Lighting Fixtures (6mm)-

Uni-directional Passageway

**In-pavement Approach Centerline Light and Cross Bar Light, In-pavement Approach Side-row Light and In-pavement Runway Threshold Wing Bar Light
APPS-12-LED, APSS-12-LED and THWS-12-LED**

Operation Manual



Please read this manual carefully before construction, installation and operation of the product.
Please keep this manual properly for further reference.

This manual is subject to change without prior notice.

Airsafe Airport Equipment Co., Ltd.

Revision Description

No.	Description	Version No.	Revised by	Approved by	Date
1	First release	V1.0	Y.MZ	C.SY	Aug. 10, 2016

Table of Content

1.0 Foreword	1
1.1 Illustrations and Meanings	2
1.2 Safety Rules and Notices	3
1.3 Quality Assurance and Responsibility	4
2.0 Introduction	5
2.1 Technical Specifications	7
2.2 Application Environment	7
2.3 Application Scope	8
2.4 Technical Parameters	8
2.5 Technical Features	9
2.6 Structure	11
2.7 Fault Detection or Lamp Bypass Functions	12
3.0 Installation	13
3.1 Installation Dimension	13
3.2 Identification of Different Types of Lighting Fixtures	14
3.3 Installation Tools	14
3.4 Screw and Torsion	15
3.5 Configuration of Lighting Fixtures and Relevant Installation Fittings	15
3.6 Installation Process	16
4.0 Replacement of Components of Lighting Fixtures	18
4.1 How to Dismount the Lighting Fixtures from Base	19
4.2 How to Open Light Body	19
4.3 How to Replace Light Source Components	20
4.4 How to Replace Prism and its Gasket Sleeve	21
4.5 How to Replace Gasket	23
4.6 Airtight Test of Lighting Fixtures	24
5.0 Operation and Control	25
5.1 Light Wiring Schematic Diagram	25
5.2 Light Intensity Adjustment and Control	25
6.0 Maintenance of Lighting Fixtures	26
6.1 Daily Maintenance	26
6.2 Regular Spot Check and Troubleshooting	27
7.0 List of Components and Ordering of Spare Articles and Accessories	28
8.0 Packaging, Transportation and Storage	30
8.1 Packaging and Weight	30
8.2 Transportation Mode	30
8.3 Storage	30

1.0 Foreword

ICAO *Airport Service Manual* Part 9 “Airport Maintenance Practices” and FAA AC150/5345-26 *Maintenance of Airport Visual Aid Facilities* are the highest criterions for site installation and maintenance of such lighting fixtures. This manual was compiled with considerable reference to these two criterions.

The content stated in this manual is absolutely important, so construction personnel must read it carefully before construction. After properly understanding the entire content of this manual, construction personnel should carry out the construction in strict accordance with the methods specified herein, to ensure that the product is safely and properly installed in place.

Routine airport maintenance personnel should carry out the routine maintenance in strict accordance with the methods specified by relevant provisions, to ensure that the lighting fixtures are in the best operation condition.

Related personnel must strictly follow safety criterion. Any personnel without specialized training is strictly forbidden to touch the lighting fixtures and devices. Live line work should be avoided under any circumstances. Construction or maintenance personnel should get acquainted with first-aid knowledge, in case of any unexpected events.

1.1 Illustrations and Meanings

- Following illustrations will appear in this manual where necessary to remind or warn construction or maintenance personnel.
- Please continue reading the subsequent content of this manual after properly understanding the meanings of these illustrations.



- To remind that the behavior may cause serious injury or death.
- ※ Detailed description will be given in the box.



- To remind that the behavior may cause injury to people or damage to product.
- ※ Detailed description will be given in the box.



- To notify that the behavior is prohibited.
- ※ Detailed description will be given in the box.

1.2 Safety Rules and Notices



- Using the light fixtures outside of airport is strictly prohibited.
- ※ Inadequate maintenance or casual touch will cause light faults.



- Using power supply other than CCR is strictly prohibited.
- ※ Other power supply may cause damage to the lighting fixtures, or even malfunctions of power supply.



- Making sure that CCR is on power-off state before the installation or maintenance of the lighting fixtures.
- ※ Current surge produced during the installation of the lighting fixtures may cause damage to light source.



- Non-professional electricians are strictly forbidden to maintain any electrical fault of the lighting fixtures.
- ※ It may damage any electrical component of the lighting fixtures or cause bigger fault.



- Live line maintenance of the lighting fixtures is strictly prohibited; in case of lightning and/or thunderstorm, maintenance of the lighting fixtures is prohibited.
- ※ It may cause electric shock accident.



- Be careful when handling the lighting fixtures.
- ※ Drop or collision may damage the parts or cause personal injury.



- Replace the lead immediately in case the jacket of second cable is damaged.
- ※ It may cause short circuit, electric shock or other failure.



- Don't touch the damaged prism or other glass directly with hands.
- ※ Glass fragments may scratch hands.



- Touching the lighting fixtures with wet hand is strictly prohibited.
- ※ It may cause electric shock or other accident.

1.3 Quality Assurance and Responsibility

Any defect in design, material or workmanship, which may occur during proper and normal use over a period of one year from date of installation but less than 15 months from date of shipment, or within the warranty period of the tender, will be repaired or replaced by manufacturer free of charge. The warranty doesn't cover the failures resulting from lamp burnt out, improper maintenance, installation or operation, or damages due to snow ploughs. Manufacturer shall not be liable to any further claims or particularly claims for damages not affecting the goods themselves.

2.0 Introduction

This manual involves the following series lighting fixtures:

- APPS-12-LED----- In-pavement Approach Centerline Light and Cross Bar Light
- APSS-12-LED----- In-pavement Approach Side-row Light
- THWS-12-LED----- In-pavement Runway Threshold Wing Bar Light

Type of In-pavement Approach Centerline Light and Cross Bar Light (APPS-12-LED):

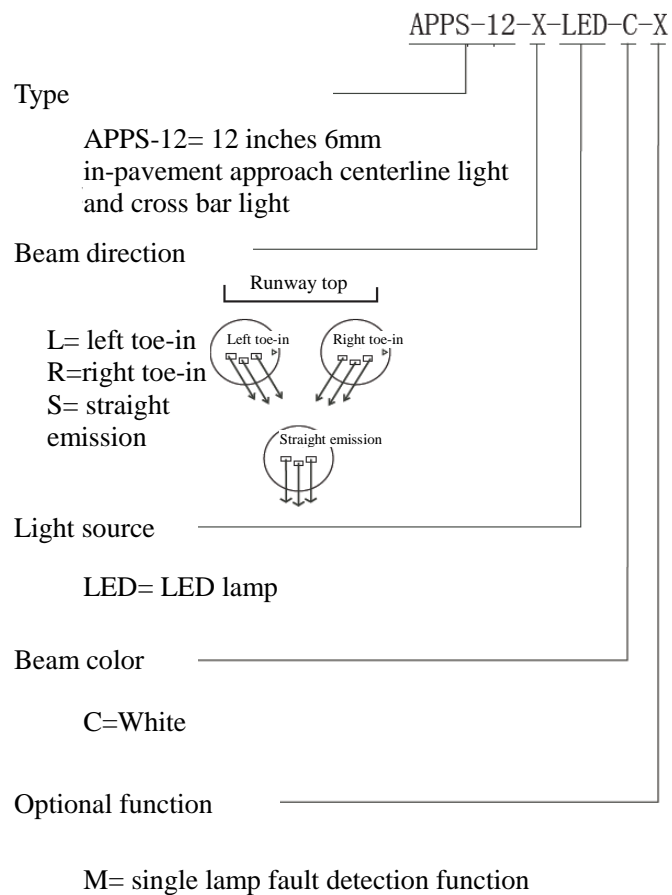

Type of In-pavement Approach Side-row Light (APSS-12-LED):

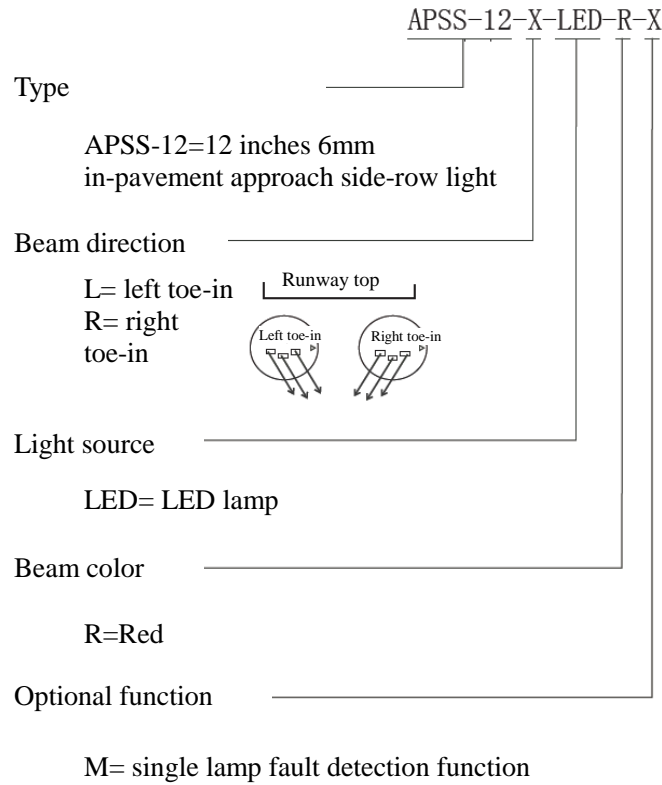

Type of In-pavement Runway Threshold Wing Bar Light (THWS-12-LED):

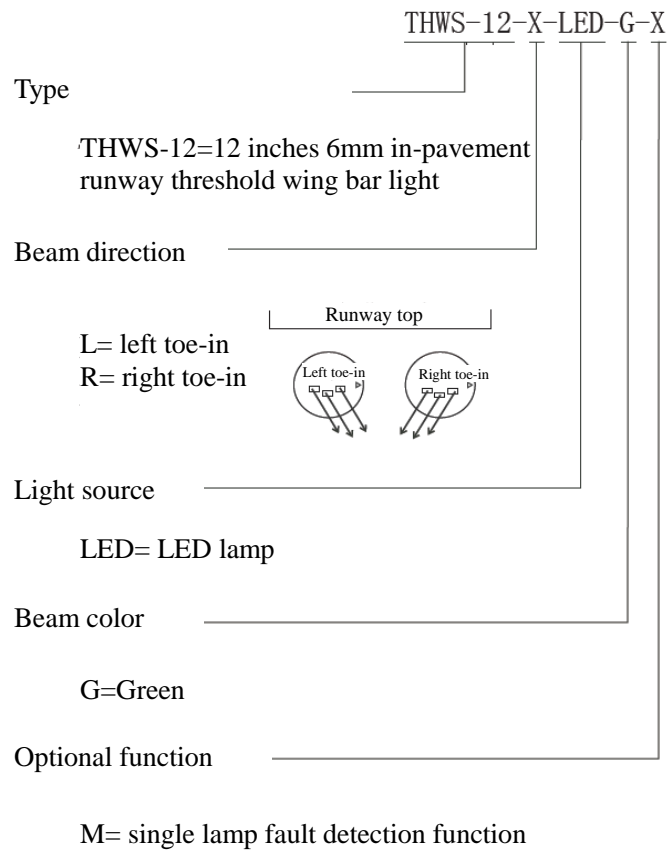

2.1 Technical Specifications

This product conforms to the provisions of the following standards or technical specifications. For dated standards or technical specifications, only the edition cited applies. For undated references, the latest edition of the referenced document (including any amendments) applies.

- International Electrotechnical Commission (IEC) TS 61827;
- Convention on International Civil Aviation Annex 14- *Aerodromes* Volume 1;
- International Civil Aviation Organization (ICAO)- *Aerodrome Design Manual*- Part 4: Visual Aids;
- Federal Aviation Administration (FAA) AC150/5345-46;
- Federal Aviation Administration (FAA) EB 67;
- GB/T 7256 *General Requirements of Lighting Fixtures for Civil Airport*;
- Department of Airport of Civil Aviation Administration of China: Advisory Circular, *Technical Requirements for Runway and Taxiway Aid Lighting Fixtures* (AC-137-CA-2015-03)
- Department of Airport of Civil Aviation Administration of China, Advisory Circular, *General Technical Requirements for Civil Airport LED Aid Lighting Fixtures* (AC-137-CA-2015-01)

2.2 Application Environment

- Altitude: below 4,000m;
- Outdoor: -55°C ~ +55°C;
- Relative air humidity: not more than 95%;
- In rain, snow, ice and water;
- Expose to corrosive salt atmosphere
- Basic earthquake intensity VII.

2.3 Application Scope

In-pavement approach centerline light and cross bar light, in-pavement approach side-row light and in-pavement runway threshold wing bar light for Categories I, II and III airports.



- Using the lighting fixtures beyond the specified scope is strictly prohibited.
- ※ Application beyond the specified scope will cause damage or risk to any component.

2.4 Technical Parameters

Description	Type	Rated Power	Power Factor	Life of Light Source
In-pavement Approach Centerline Light and Cross Bar Light	APPS-12-S-LED-C-M	70VA	>0.9	≥50,000h
	APPS-12-L-LED-C-M	70VA	>0.9	≥50,000h
	APPS-12-R-LED-C-M	70VA	>0.9	≥50,000h
In-pavement Approach Side-row Light	APSS-12-L-LED-R-M	45VA	>0.9	≥50,000h
	APSS-12-R-LED-R-M	45VA	>0.9	≥50,000h
In-pavement Runway Threshold Wing Bar Light	THWS-12-L-LED-G-M	65VA	>0.9	≥50,000h
	THWS-12-R-LED-G-M	65VA	>0.9	≥50,000h

2.5 Technical Features

- Long life, energy saving, maintenance free and other characteristics of LED will bring huge economic benefits to customers;
- Proprietary prism structure and manufacturing process, making the optical efficiency excellent;
- Strict LED color management ensures the consistency of light color;
- Dimming curve of the lighting fixtures is consistent with the change of halogen lamp, and meets the requirements of FAA;
- Proprietary drive circuit and thermal management solution greatly improve the reliability and service life of the lighting fixtures.
- Power factor is greater than 0.9, which minimizes the grid interference;
- Optional single lamp fault detection function enables the light to be open as halogen lamp once LED fails;
- Specifically designed lighting fixture structure and the lighting fixture is only 6.35mm protruded above the pavement;
- The luminous surface of the upper cover of the lighting fixture is flat, and thus it is difficult for ponding and the luminous efficiency is high;
- The upper cover of the lighting fixture employs the constant strength design and forging process, with good mechanical property and high bearing capacity and shock resistance capacity;
- The upper cover of the lighting fixture is smooth, without sharp corner angle to ensure that the aero tyre is not damaged;
- Main body of the lighting fixtures is made of the special high conduction aluminum alloy material and thus the lighting fixtures have good heat dissipation;
- Main body of the lighting fixtures is made of aluminum alloy material with special anodizing surface treatment, and all fasteners are made of stainless steel, thus being applicable to all kinds of harsh environment;

- High precision components machining ensures dimensional quality and precision of the lighting fixtures.
- The overall IP rating of the lighting fixtures reaches IP68, which may bear 138KPa internal pressure or water pressure formed by impact of the aircraft on the window;
- Optional double plugs respectively control the light of two windows, so as to achieve the intelligent circuit control;
- The components are of modularized design for common use, which are applicable to various 12 inches LED in-pavement runway lights (6mm), effectively reducing the spare parts inventory.

2.6 Structure

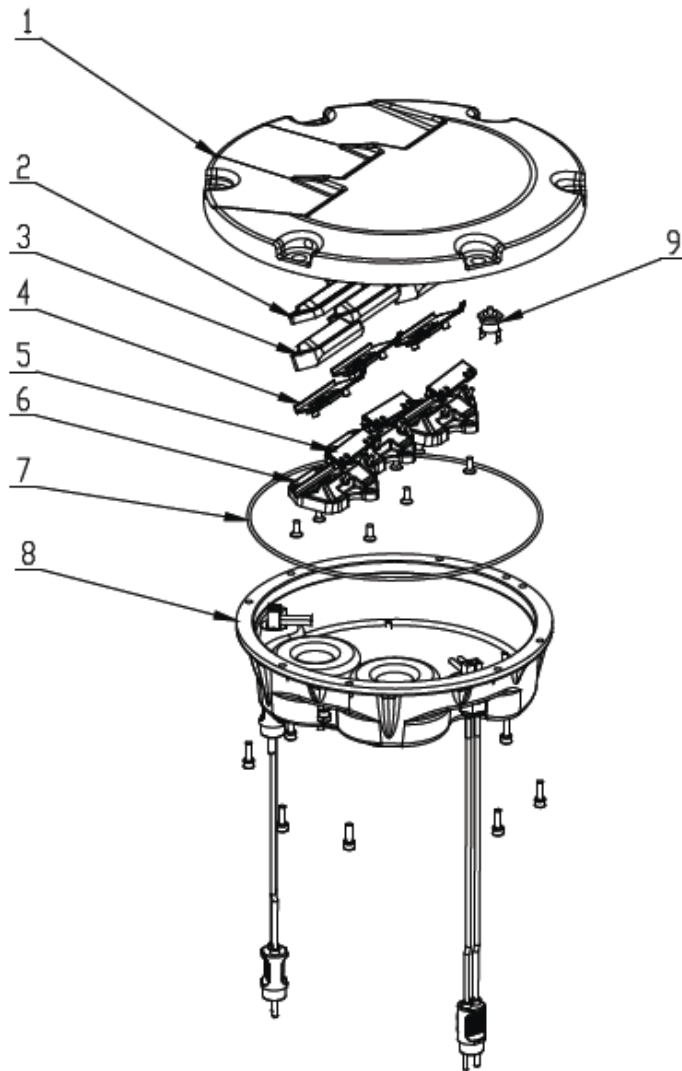

1. Upper cover 2. Prism gasket sleeve 3. Prism 4. LED lamp assy 5. Prism gasket
6. Prism pressing bracket 7. Light body gasket 8. Inner cover assy 9. Temperature control switch

2.7 Fault Detection or Lamp Bypass Functions

This product complies with the requirements of FAA EB67 and GB/T 7256, and integrates single lamp fault detection function; Or, it can provide the option of lamp bypass function in accordance with the requirements of FAA AC150-5345/46.

Single lamp fault detection function: The light will take automatic action to cut off the input when any malfunction occurs on the lamp and achieve an effect similar as the open circuit of ordinary halogen light once it is burnt. This function is generally used in conjunction with single lamp controller, to help single lamp control and monitoring system to identify any failed light. And it is integrated into the interior of the lighting fixtures, without need of any external device. Please specify this function during the ordering if needed.

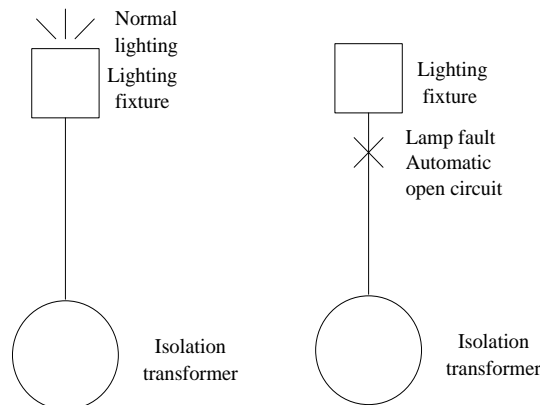

- In case of no special requirements, 100W isolation transformer lighting is recommended.
- ※ Any isolation transformer whose power is greater than 100W shall not be used for the fixture that has the single lamp fault detection function.

Lamp bypass function: After any failure occurs to the lamp, relatively, the input terminal of light will be short to the isolation transformer. This function is generally applicable to occasions that one isolation transformer carries multiple lighting fixtures. If one or more of these lighting fixtures is or are damaged, the remaining lighting fixtures will not go out thereby. This function is integrated into the interior of the lighting fixtures, without need of any external device. Please specify this function during the ordering if needed.

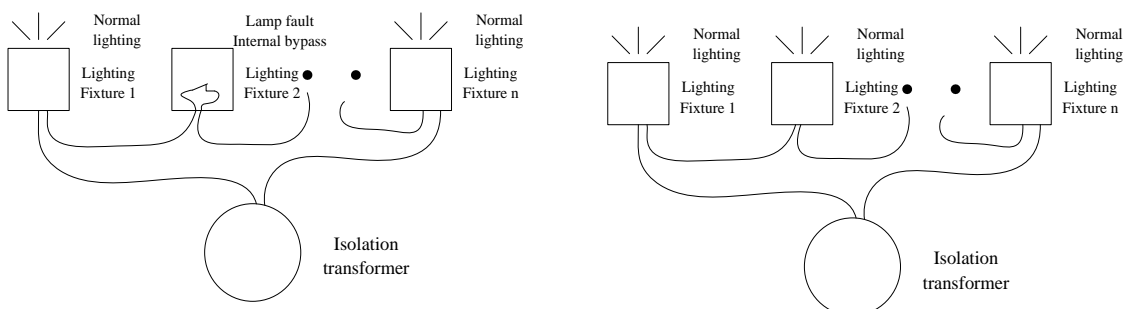

3.0 Installation

Requirements for installation should be learned thoroughly before installation including installation tools and site requirement, etc., to avoid malfunction of the light due to incorrect installation

3.1 Installation Dimension

- Directly mounted on the 12 inches deep base (Figure 3-1).
- Directly mounted on the 12 inches shallow base (Figure 3-2).

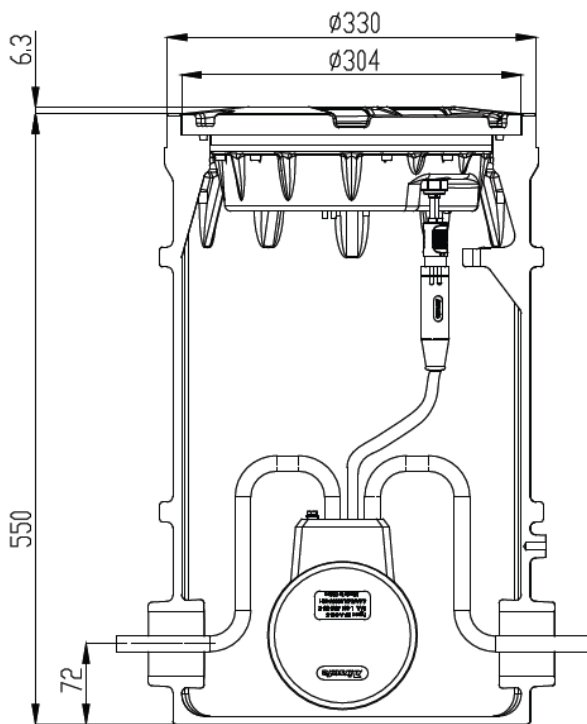

Figure 3-1

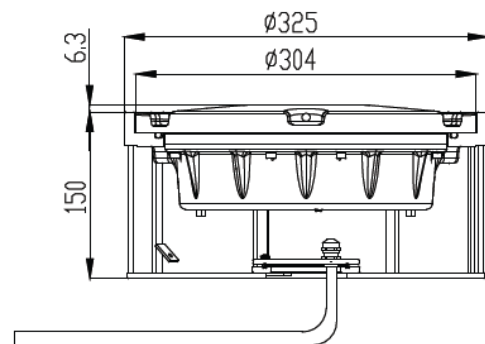
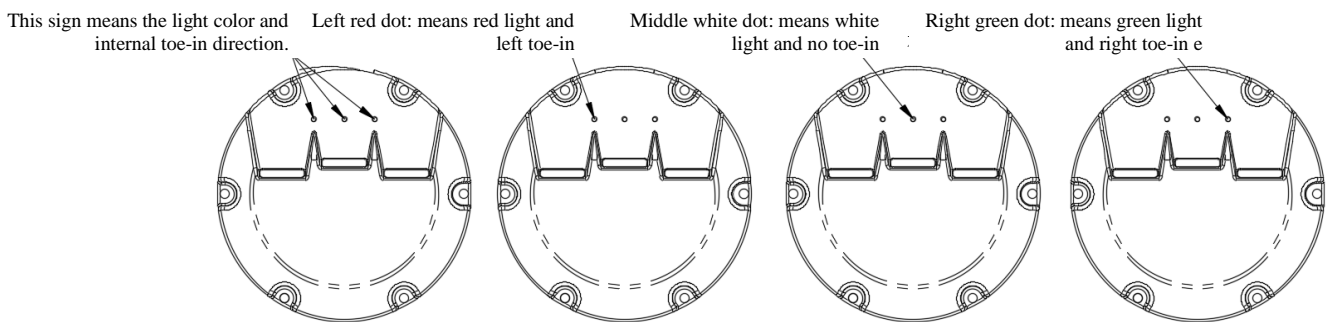

Figure 3-2

3.2 Identification of Different Types of Lighting Fixtures

- The model of each lighting fixture is attached to its bottom.
- The colorful dot identification mark is attached to the light outlet of each lighting fixture, respectively meaning the luminous color and direction of the window where the colorful dot is located.
- According to the specific provisions of FAA, correctly select the lighting fixtures and ensure their window directions.



- Before installing the lighting fixture, confirm the window color and luminous direction.
- ✘ Avoid rework or other problems.

3.3 Installation Tools

Choosing right tools not only can ensure the correct and reliable installation of the lighting fixtures, but also can reduce unnecessary safety accidents. *Special Tools* listed in the table may be purchased from the manufacturer or any distributor. Universal tools are available on local hardware market. Please pay attention to measurement range during procurement.

- Universal tool: Torque wrench: be used to tighten the screw, which may be used with various sleeve wrenches and directly purchased from various hardware stores, manufacturer or agent.

Recommended range is 10-40N·m.

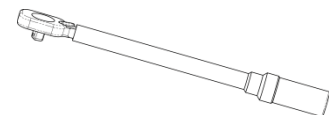

- Universal tool- Torque screwdriver: be used to dismount screw, equipped with PH2 cross screwdriver, and sellable in various hardware stores.

Recommended range is 1-6N.m

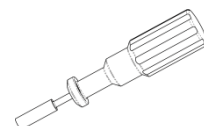

3.4 Screw and Torsion

The torque listed in this section is only for reference by maintenance personnel. Correct fastening force of screw can ensure normal operation of the lighting fixtures. If screw is too tight, it will easily damage the lighting fixtures; on the contrary, if screw is easy to fly out, it may cause an accident.

Serial No.	Screw Type	Tool	Torque
1	M10	Torque wrench with 17# sleeve	25 N·m
2	M5	Force measuring screwdriver with cross screwdriver (PH2)	3 N·m
3	M4	Force measuring screwdriver with cross screwdriver (PH2)	1.5 N·m
4	M3	Force measuring screwdriver with cross screwdriver (PH1)	0.63 N·m



- Please use torque wrench or other special tool for installation.
- ※ Informal tools may cause damage to fasteners or personal injury.

3.5 Configuration of Lighting Fixtures and Relevant Installation Fittings

- 1、 M10×30 screw
- 2、 Ø10 spring washer
- 3、 Lighting fixture
- 4、 12 inches shallow base
- 5、 A7 twin-core receptacle

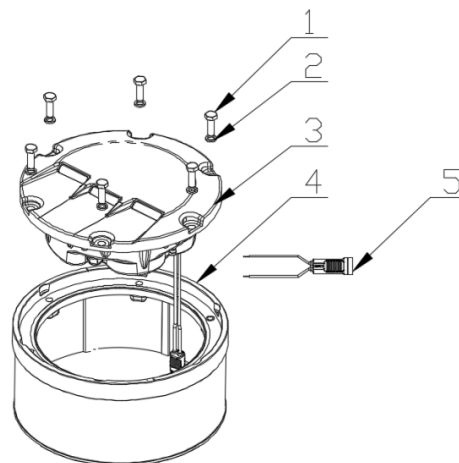

3.6 Installation Process

The installation process of lighting fixtures includes settings of the pavement mounting hole, wiring, base pre-burial and installation of lighting fixtures. The installation of lighting fixtures will greatly impact their use and service life. The manufacturer recommends that all installers should receive the professional training.

3.6.1 Base installation

a There is scribed line on the base edge and the luminous direction of the lighting fixtures is often parallel to the runway centerline. When the lighting fixture base with the internal toe-in requirements is installed, the internal inclination angle is not considered. The scribed line is parallel to or overlapped with the centerline;

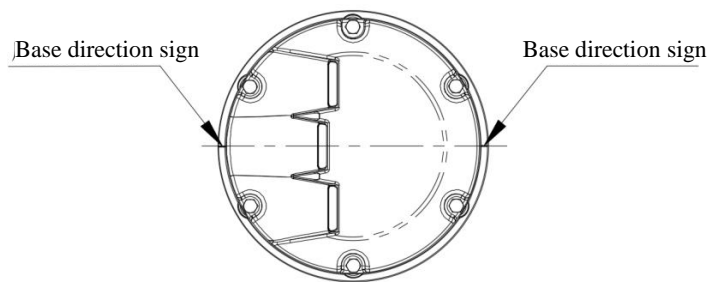

b The base embedment is constructed according to the airport design plan and the manufacturer does not recommend the plan; the base entry may be divided into the side entry and bottom entry.

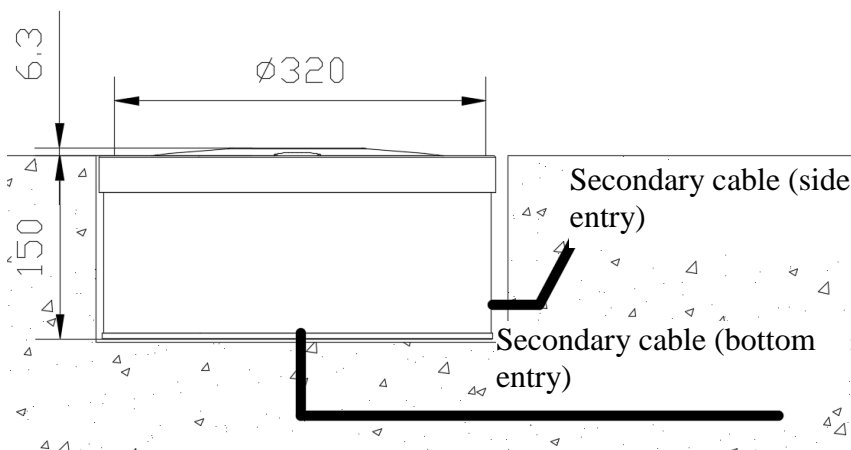

3.6.2 Installation

a Before installing the lighting fixtures, clean the waste in the seal groove to keep good seal. Put the O-gasket (part No.: 41115) into the working position in the seal groove.

b Connect the secondary plug of the lighting fixtures with the base receptacle to keep good contact.

c Load the lighting fixtures into the base, identify the direction, screw the screws into the screw holes in successive and please note the torsion when screwing them.

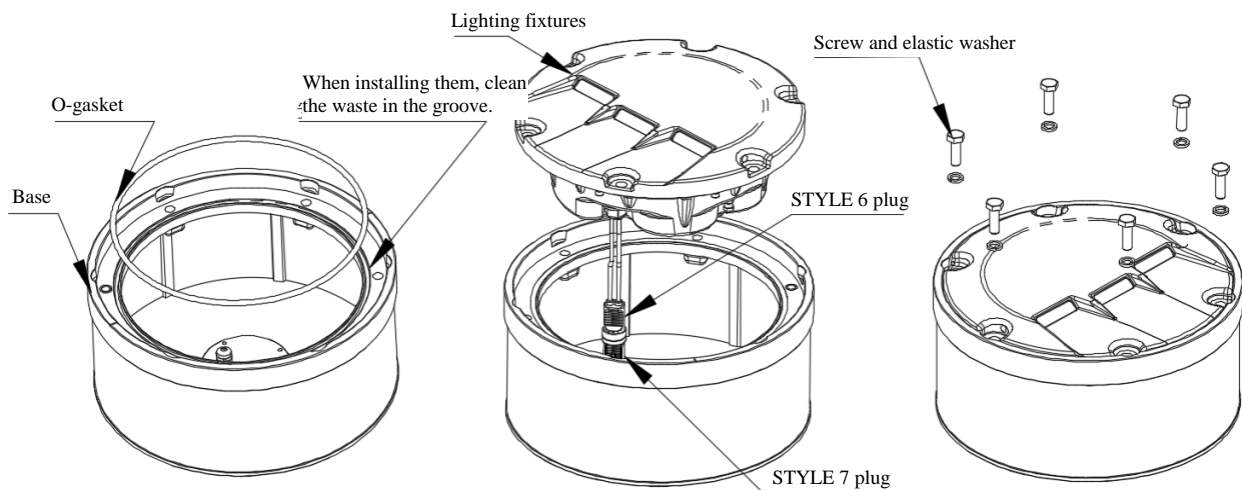

- The ground lead must be connected in strict accordance with the provisions.
- ※ During daily maintenance, electric shock accident may be caused.



- During installation, the oily lubricating agent shall not be used to lubricate the sealing components.
- ※ The oily lubricant may cause aging or fault of the sealing components.



- The weight of the isolation transformer shall not be directly applied to the lead.
- ※ It may cause cable break, short circuit, drop, injury or other faults.



- During installation, the lead shall not be damaged by the lighting fixtures.
- ※ It may cause electric leakage or short circuit of the lighting fixtures.



- Directly pulling the lead is prohibited when the lighting fixtures are handled.
- ※ It may cause line break, short circuit, drop, injury or other faults.

4.0 Replacement of Components of Lighting Fixtures

When any damage or failure occurs to any consumable or other component of the lighting fixtures, it is required to timely dismantle the lighting fixtures for replacement of the component. Replacement of components needs to dismantle the lighting fixtures, so any minor error will cause adverse consequences. The manufacturer requires users to attach importance to the following warnings. When dismantling the lighting fixtures, please take care to perform overall inspection for them, replace some vulnerable parts and perform the air seal test to ensure their performance after dismantling.



- Replacement of components must be conducted by personnel who have received professional training.
- ※ To avoid various failures of the lighting fixtures.



- It is suggested that maintenance of the lighting fixtures be carried out in lighting station or workshop.
- ※ Any impurities mixed in the lighting fixtures may cause failure of the lighting fixtures.



- When cleaning the prism surface, avoid touching the filter with film coated.
- ※ It may damage the filter with film coated or impact the optimal optical performance of the lighting fixtures.



- When the lighting fixtures are dismantled each time, M10×30 complete set of fasteners shall be replaced.
- ※ The fatigue damage of the screw and elastic failure of the spring washer may cause accident.



- The manufacturer suggests that various gaskets should be replaced during each maintenance of the lighting fixtures.
- ※ Aging and damage of gaskets are the main reasons for the leakage of lighting fixtures.

4.1 How to Dismount the Lighting Fixtures from Base

- Dismount M10×30 screw, washer and spring washer (see Figure 4-1);
- Stretch into the pinch bar hole with two screwdrivers and vertically unscrew the lighting fixtures (see Figure 4-2).

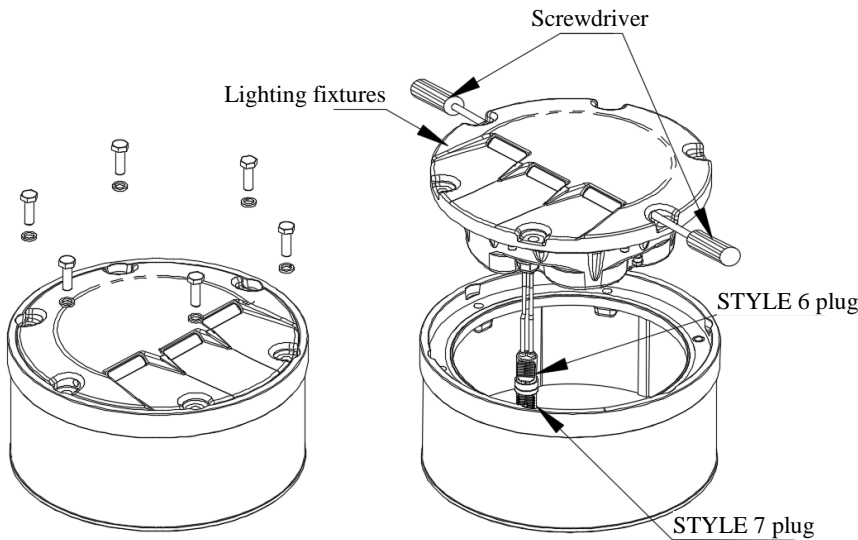

Figure 4-1

Figure 4-2



- When the lighting fixtures are dismantled, please use the special handle supplied by the manufacturer.
- ※ The lighting fixture drop may cause personal injury.

4.2 How to Open Light Body

- Place the top of the lighting fixtures downwards and dismount 8 M5×12 screws (Figure 4-3);
- Separate the upper cover and inner cover on the lighting fixtures (Figure 4-4);

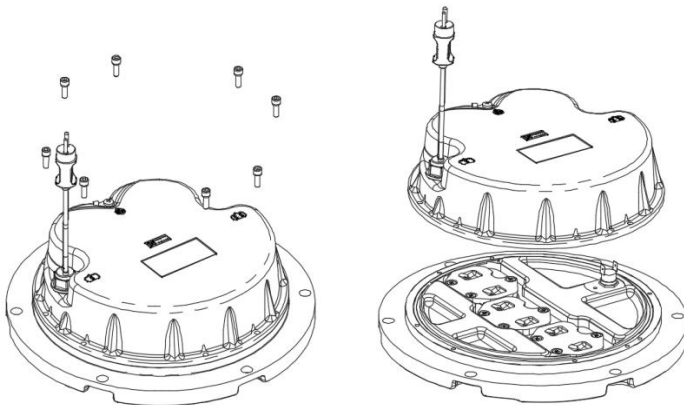

Figure 4-3

Figure 4-4

4.3 How to Replace Light Source Components

- Separate the upper cover and inner cover with the method set forth in 4.2;
- Pull out the light source component pin from the light source binding post of the circuit board of the inner cover component (Figure 4-5);
- Dismount the screws shown in Figure in succession and take out the light source component (Figure 4-6);
- Fetch the new light source component, assemble it onto the upper cover with the above-mentioned method and insert its pin into the binding post. During this process, please note the installation direction of the light source component. There are 4 fixed light source holes and the installation position depends on different combinations of the holes (Figure 4-7).

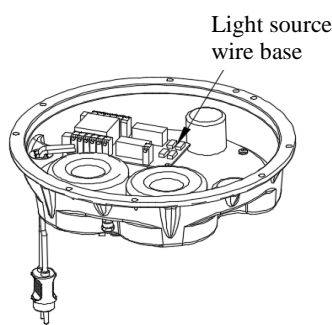

Figure 4-5

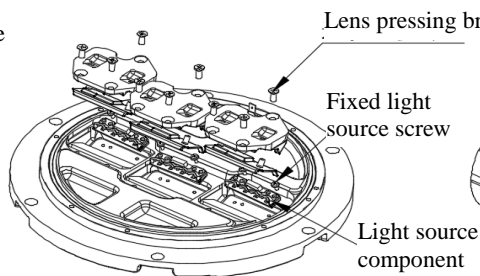

Figure 4-6

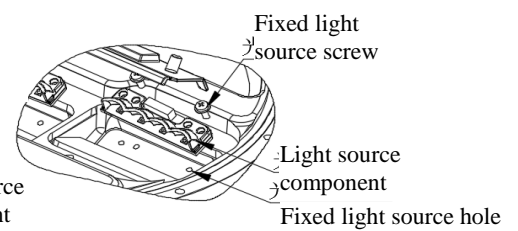

Figure 4-7



- Making sure that the light source component is correctly installed.
- ※ The light source suggested by the manufacturer is helpful for its normal service life.



- Making sure that the light source component is installed on the correct position.
- ※ Otherwise it may impact the luminous effects of the lighting fixtures.



- Touching the light source particle of the light source component directly with hands is prohibited. During operation, the clean white gloves shall be worn.
- ※ The grease on the skin may damage the light source particle during use.



- Touching the internal part of the reflector with hands is prohibited.
- ※ Otherwise it may cause low efficiency of the light source component.

4.4 How to Replace Prism and its Gasket Sleeve

- Separate the upper cover and inner cover with the method set forth in 4.2;
- With the socket head wrench, dismount M5×12 screws and take down the prism pressing bracket, prism washer, lens and lens gasket sleeve in succession (see Figures 4-8 and 4-9);
- Cover the new lens gasket sleeve onto the lens and ensure that the gasket sleeve is uniform (see Figure 4-10).
- Push the lens and its gasket sleeve to the working position on the upper cover. When pushing them, water clean water at the window and wipe the lens surface with the diethyl ether to keep it clean (see Figure 4-11);
- Install the light source component with the method set forth in 4.3 in place;
- Place the prism pressing bracket and lens washer to the working position and screw the M5×12 screws into the threaded holes after dipping a little of anaerobic adhesive (see Figures 4-12 and 4-13);
- After the gasket sleeve is placed, check whether it is exposed at the window. In case of much exposed, it shall be reloaded according to the above-mentioned process. In case of a small part exposed, cut it with a knife (Figure 4-14).

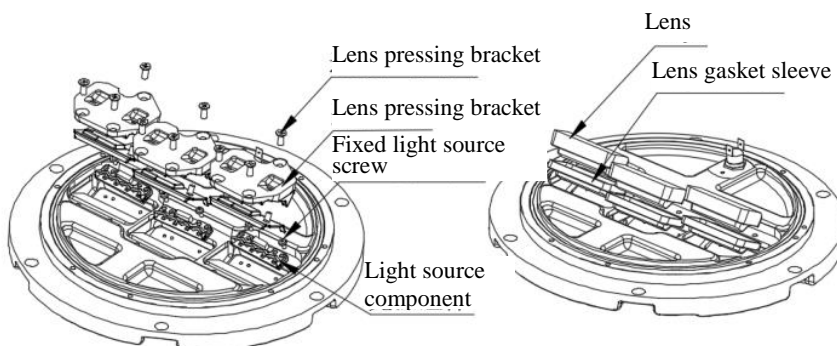

Figure 4-8

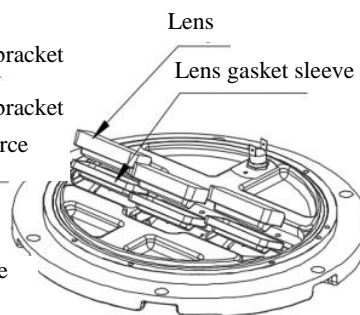

Figure 4-9

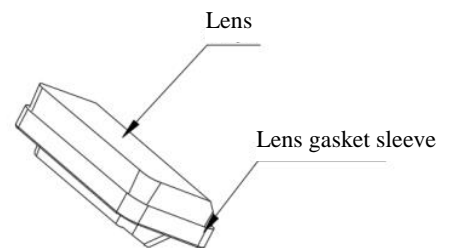

Figure 4-10

In case of a small part exposed, cut it with a knife.

如此处少量外露，则用小刀将其切除

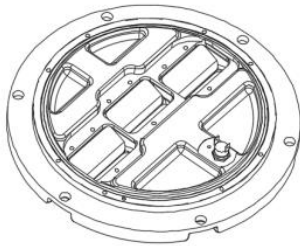

Figure 4-11

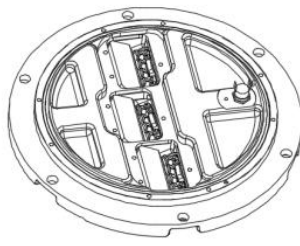

Figure 4-12

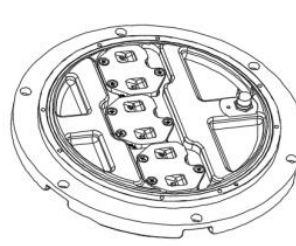

Figure 4-13

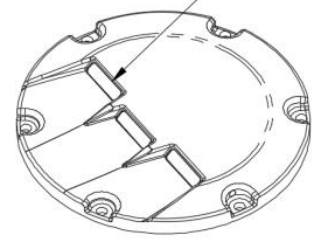

Figure 4-14



- The old rubber gasket sleeve shall not be used repeatedly.
- ※ Aging and damage of the rubber gasket sleeve may cause water seepage and leakage of the lighting fixtures.



- The force shall be uniformly applied to the screws at the opposite angles, which shall be screwed gradually.
- ※ Otherwise it may cause damage to the prism or leakage of the upper cover.



- Ensure that the gasket is located in the seal groove of the upper cover to prevent it from being cut.
- ※ It may cause lighting fixture leakage.

4.5 How to Replace Gasket

- Dismount the screw connecting the inner cover and upper cover to separate them (see Figure 4-15);
- Take out the old gasket from the seal groove of the upper cover (see Figure 4-16);
- Wash the waste in the seal groove with water or ethyl alcohol to keep the seal groove clean (see Figure 4-17);
- Fetch a new gasket and place it into the seal groove. It shall be in the seal groove naturally (see Figure 4-18).
- Take out the inner cover, make the pin aim at the pin hole and connect the upper cover and inner cover with the screw (see Figure 4-19).

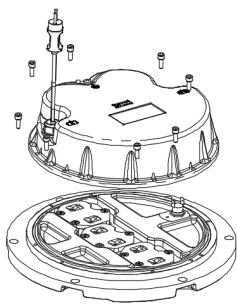

Figure 4-15

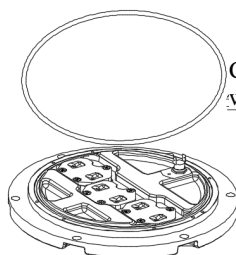

Figure 4-16

Clean the waste in the seal groove when installing the gasket.

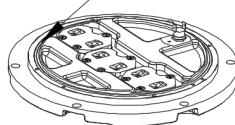

Figure 4-17

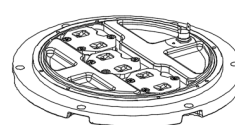

Figure 4-18

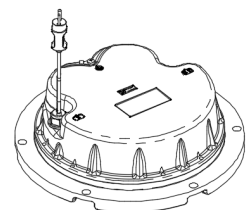

Figure 4-19



- Carefully check the gasket and seal groove to ensure that there are no impurities.
- ※ The impurity inclusion is the main cause of lighting fixture leakage.



- Ensure that the lighting fixture gasket is located in the seal groove of the upper cover to prevent it from being cut.
- ※ It may cause lighting fixture leakage.



- The force shall be uniformly applied to the screws at the opposite angles, which shall be screwed gradually.
- ※ Otherwise improper assembly may cause water seepage of the lighting fixtures.

4.6 Airtight Test of Lighting Fixtures

- Unscrew the valve cap at the lighting fixture bottom (see Figure 4-20).
- Prepare 138Kpa air source (the air pressure shall not be greater than 150Kpa) and applicable air gun (air tube), inflate the air by aiming at the valve (Figure 4-21) until the air pressure in the lighting fixture meets the requirements. Put this lighting fixture into the water with the depth of 76mm for at least 1min and check whether there are bubbles under the state of static water surface. If not, it means that the sealing property of the lighting fixture is good, otherwise it shall be deemed that the lighting fixture has leakage.
- After detection, release the air pressure in the lighting fixture with the air valve of the valve core, re-screw the valve cap and put it into use (Figure 4-22). In case of leakage, check the causes according to the previous prompts and repeat the whole lighting fixture disassembly and assembly process or return it to the factory for maintenance.

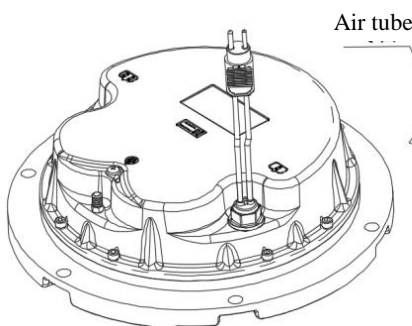

Figure 4-20

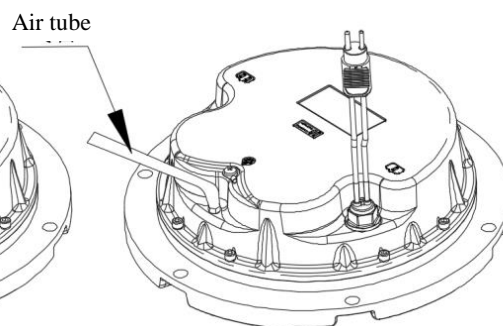

Figure 4-21

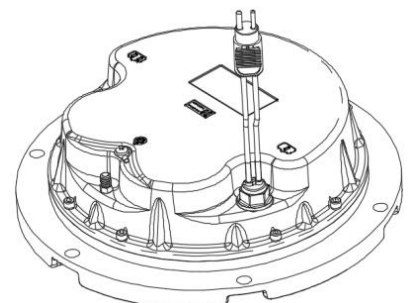

Figure 4-22



- After installation, the leakage test must be performed according to the requirements.
- ※ Improper assembly may cause leakage of the lighting fixtures.



- When the valve cap is unscrewed, please do not loosen the valve.
- ※ Otherwise it may cause leakage of the lighting fixtures.

5.0 Operation and Control

The lighting fixtures are applicable to CCR power supply 6.6A circuit special for airports, which forms a secondary circuit with the lighting fixtures through secondary outgoing line of isolation transformer connected on primary circuit. Due to the use of isolation transformer, the damage of lamp of single lighting fixture will not affect whole series circuit.

5.1 Light Wiring Schematic Diagram

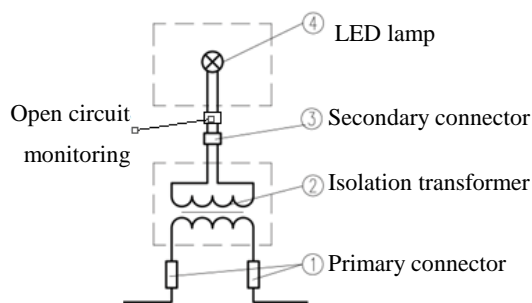

5.2 Light Intensity Adjustment and Control

In actual use, according to weather visibility, light intensity of the lighting fixtures may be adjusted through different current output by CCR, and varies significantly.

If it is used on occasion of lower than rated current (6.6A), it may greatly improve the service life of lamp.

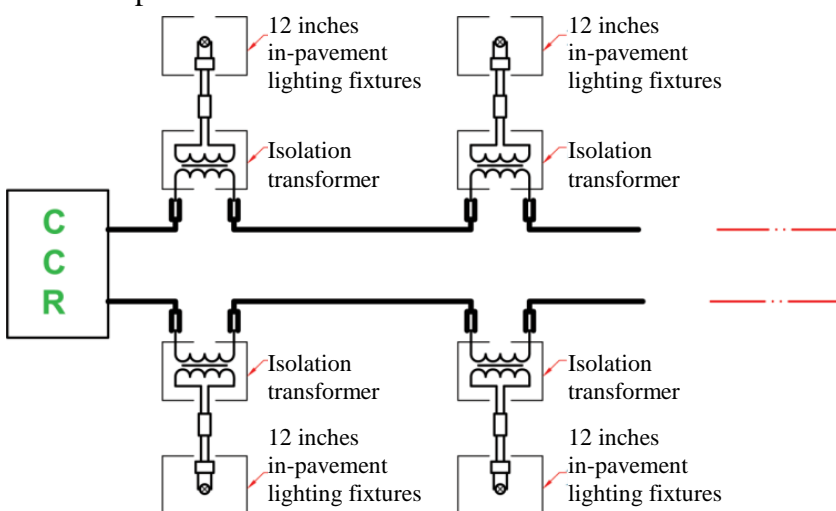

- Using power supply other than CCR is strictly prohibited.
- ⊗ Other power supply may cause damage to light source or other component of the lighting fixtures, or even malfunctions of power supply.

6.0 Maintenance of Lighting Fixtures

Suggestions for daily maintenance provided in this section are only for reference. Airports may formulate their own daily maintenance guidelines with reference to other provisions or maintenance experience of airport staff; the manufacturer does not provide any hard-and-fast rules. Maintenance of the lighting fixtures for airports shall be conducted by professionals as stated in 1.0 Foreword.

6.1 Daily Maintenance

Interval	Check	Activity
Every day	No light output or flashing	Replace LED lamp assy.
	Light output is lower	<ol style="list-style-type: none"> 1. Clean the prism surface if it is dirty. 2. Check deviation or moisture of the lighting fixtures. 3. Check aging or displacement of LED.
Every week	Obstacles to light output channel	Clean the path and prism surface.
Every month	Existence of moisture and water (Visual check of internal surface of prism)	<ol style="list-style-type: none"> 1. Open the body. 2. Clean, dry and check. 3. Replace the body gasket and other parts damaged.
Every two months	Tighten the screws	<p>Check whether screw for tightening light body is locked.</p> <p>Use the tools such as wrench and sealant by referring to the Table in Section 3.4.</p>
Every half a year	Water in the base	<ol style="list-style-type: none"> 1. Pump out the water in the base. 2. Move and dismantle it and observe the damage to the lighting fixtures by water. 3. Dispose of the water inlet.
After snow removal	Damage to lighting fixtures	<ol style="list-style-type: none"> 1. Replace seriously damaged light.
After snow removal	Light output is lower	<ol style="list-style-type: none"> 1. Sweep the snow on the window with a powerful sweeper. 2. Clean the prism surface if it is dirty. 3. Check deviation or moisture of the lighting fixtures. 4. Check aging or displacement of LED.

6.2 Regular Spot Check and Troubleshooting

Serial No.	Failure Phenomenon	Possible Reasons	Countermeasures
1	No light output or flashing	LED aging or other unknown failure Power of the isolation transformer of greater than 100W.	Replace the LED lamp component or driver or return the lighting fixtures to the manufacturer for maintenance.
2	The lighting fixtures is darker	The prism surface is dirty.	Clean the prism surface.
3	Existence of moisture and water	The prism or gasket is damaged.	Replace the prism or gasket.



- The manufacturer suggests that times of daily maintenance should be increased in rainy season.
- ※ To ensure normal operation of lighting fixtures.



- The manufacturer suggests that the lighting fixtures should be systematically replaced when the service life of the LED lamp reaches 80%.
- ※ To ensure the consistency of light intensity of whole circuit.



- It is necessary to use torque wrench. Power wrench is strictly prohibited.
- ※ Otherwise, it may damage screw and thread, and thus cause an accident.

7.0 List of Components and Ordering of Spare Articles and Accessories

The table in this chapter lists the components, spare articles and accessories of this product and relevant ordering information. Spare articles and accessories of this product needs to be ordered additionally, and the manufacturer accepts the order in assembly mode and separate order of components. When ordering, please contact the manufacturer or any distributor according to order number listed in the table. The manufacturer suggests that some important components should be purchased from original factory to ensure various indicators of the lighting fixtures.

List of components and spare articles:

Structure No.	Component Name	Order No.	Description
1	Upper cover	213B3	Upper cover (12) LED-H6-Uni-directional three-window
2	Lens gasket sleeve	43117	Lens gasket sleeve (61×28)-H6
3	Lens	31158	Lens(61X28)-H6
4	LED lamp	932053-C(AGL)	LED lamp assy C(AGL)
		932053-R(APP)	LED lamp assy R(APP)
		932053-G(APP)	LED lamp assy G(APP)
5	Prism gasket	43316	Prism gasket (67X21)
6	Prism pressing bracket	43241	Prism pressing bracket (71X65)
7	Light body gasket	41135	O- gasket 228.27X2.62
8	Inner cap components	921431	12 inches inner cover component 6mm-1P
9	Temperature control switch	48511	Temperature control switch (35-45°C)

List of supporting accessories of this product is as follows (needing additional order):

Serial No.	Order No.	Description
1	927151	12 inches shallow base component (side entry)
2	927156	12 inches shallow base component (bottom entry)
3	82732X	12 inches deep base (H550) assy
4	70703	A7 twin-core receptacle
5	41115	12 inches base O- gasket
6	70703	Secondary receptacle A7
7	ITF-065-066	Isolation transformer 65W
8	ITF-100-066	Isolation transformer 100W



- When the prism cannot work properly, please order it from our company.
- ※ The prism of other brands may impact the luminous angle and light intensity of the lighting fixtures.



- If secondary plug is damaged, please order it from our company.
- ※ Other brand plug may cause light leakage and other failures.

8.0 Packaging, Transportation and Storage

8.1 Packaging and Weight

Packaging: 1 pcs / box

Gross weight: 9.7 KG / box

Volume: 330*330*150mm³

Packaging: 1 pcs / box (including 12 inches shallow base)

Gross weight: 14.26 KG / box

Volume: 330*330*185mm³

8.2 Transportation Mode

Well packed products may be transported in three modes- railway, highway and air according to factors such as transportation distance, quantity of lights and delivery cycle.

8.3 Storage

This product shall be stored in a place which is dry, well ventilated and far away from heat source and has no caustic gas. Custody should be checked on a regular basis.

The final right to interpret this manual is reserved by Airsafe Airport Equipment Co., Ltd.

Thanks for your purchasing and using AIRSAFE product!

Address: No. 38, Anxin Road, Xuhang Town,
Jiading District, Shanghai, China
Postal Code: 201800
Tel.: 021-53540453
Fax: 021-63643114
E-mail: sales@airsafe.com.cn