

LT864

Medium Intensity Solar Aviation Obstruction Light



Products description and application



Medium intensity aviation obstruction light type B is mainly used for marking the buildings which can do harm to aircraft, Red flashing/steady burning working mode at night; Combined with advanced LED, optics and control technology to satisfied the harshest application;

Applying to tower, chimney, high tech building, bridge, Port devise, Construction machinery, wind power generator etc for air traffic warning.

Applying to obstacle of 45-105m or for the high tech building on position of 45-105m.

Applying to high salt area.

Features

- 0 Surface electrostatic powder sprayed yellow, anti-vibration, corrosion resistance;
- 0 PC lampshade with UV and impact resistance; flammability grade: UL94-V0;
- 0 Waterproof silicone sealing structure;
- 0 The light source adopts LED process, long life, low energy consumption and high efficiency;
- 0 Built-in connect terminals, and will connect well inside before Ex-work;
- 0 GPS Synchronization (can be customized);
- 0 Failover function(customized).

Specifications

Electrical parameters		Mechanical parameters	
Power supply	18V 12W silicon solar panel 12V 12AHbattery	Storage temperature	-40 °C ~ +70 °C
Fault alarm	Base layer working, top layer standby(need customized)	Operating temperature	-40 °C ~ +55 °C
Power consumption	30W	Operating humidity	10% ~ 95% RH(Non-condensing)
Lightning surge	IEC61000-4-5 L- L 2kV , IEC61000-4-5 L-G 4kV	IP rate	IP65
Electrostatic discharge	IEC61000-4-2 Contact discharge 8kV	Reference weight	11kg
Continuous working time in cloudy days	>90hrs(environment temperature 25 °C)	Material	base: aluminium, lamp house: PC Chassis: cold rolled plate / stainless steel (spray)
Optical parameters			
Standard	ICAO; FAA-L864;MH-T6012-2015		
Light source	LED		
Light lifespan	≥100,000h		
Color	Red(others can be customized)		
Intensity	2000 ± 25% cd		
Horizontal degree	360°		
Vertical degree	≥3°		
Operating type	Flashing		
Flashing Rate	20times/min		

LT864

Medium Intensity Solar Aviation Obstruction Light



Flashing continue time 100ms
On/Off level 50-200lux

Mounting dimensions

Dimension :mm

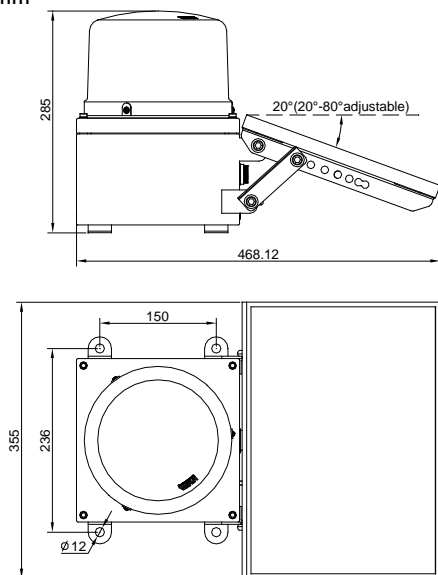

Angle 20° installation diagram

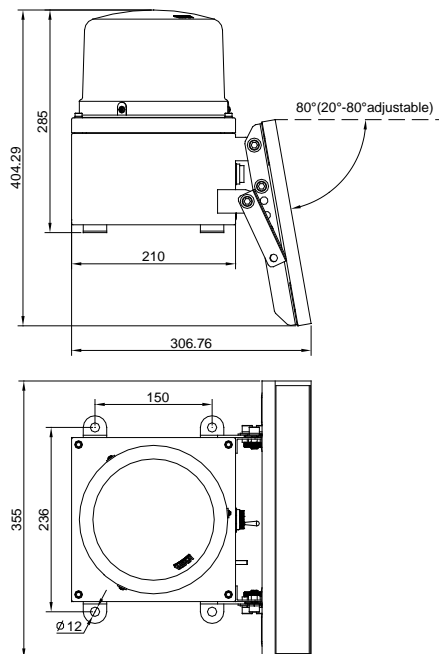

Angle 80° installation diagram

Wiring diagram

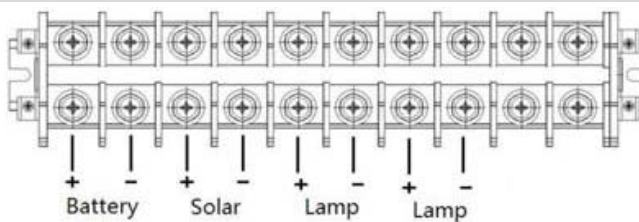

Pack material

Open the box, inside material :

Case(with Lamp) 1 piece

Solar panel(Mounting bracket and plug) 1 piece

M8*20 Allen stainless steel screws 4 pieces

Ø 8 Stainless steel plain washers 4 pieces

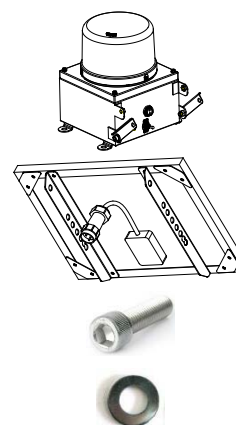

LT864

Medium Intensity Solar Aviation Obstruction Light



- Ø8 Spring washer 4 pieces
- M8 Hexagon nut 2 pieces
- M8 Allen wrench 1 piece



Installation method of use

- Use the M8 wrench to loosen the case on the M8*20 socket cap screw, Angle adjust bracket can rotate freely; Pic 1 as below:

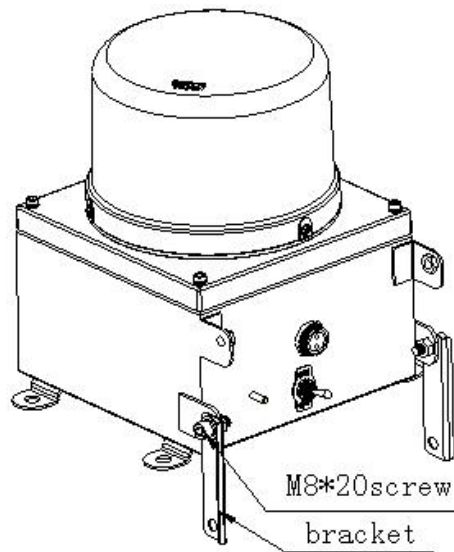

Pic 1

- Fixed solar panel:
 - a. Firstly, the 2 sets of M8 screw assembly (Screw, spring washers flat pad) connect solar panel and case together; Pic 2 as below;
Noted: Ensure two fixed together, no need too tight.

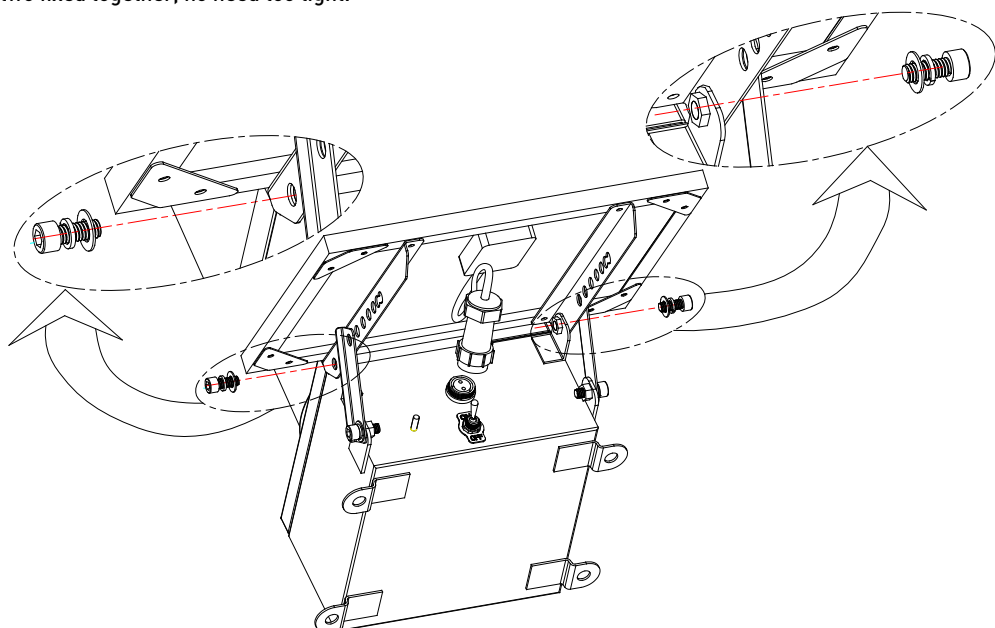

Pic 2

- b. Use 2 sets of M8 screws assembly (Screw, spring washers, flat pad) with M8 nut put solar panels and angle adjustment bracket together, pic 3 as below:

LT864

Medium Intensity Solar Aviation Obstruction Light



Noted: Install hole location according to solar panels and horizontal plane angle, each hole please see pic 4. The angle of the panels with horizontal plane shall be equal to the latitude. Solar panels are adjustable between 20° and 80° ,

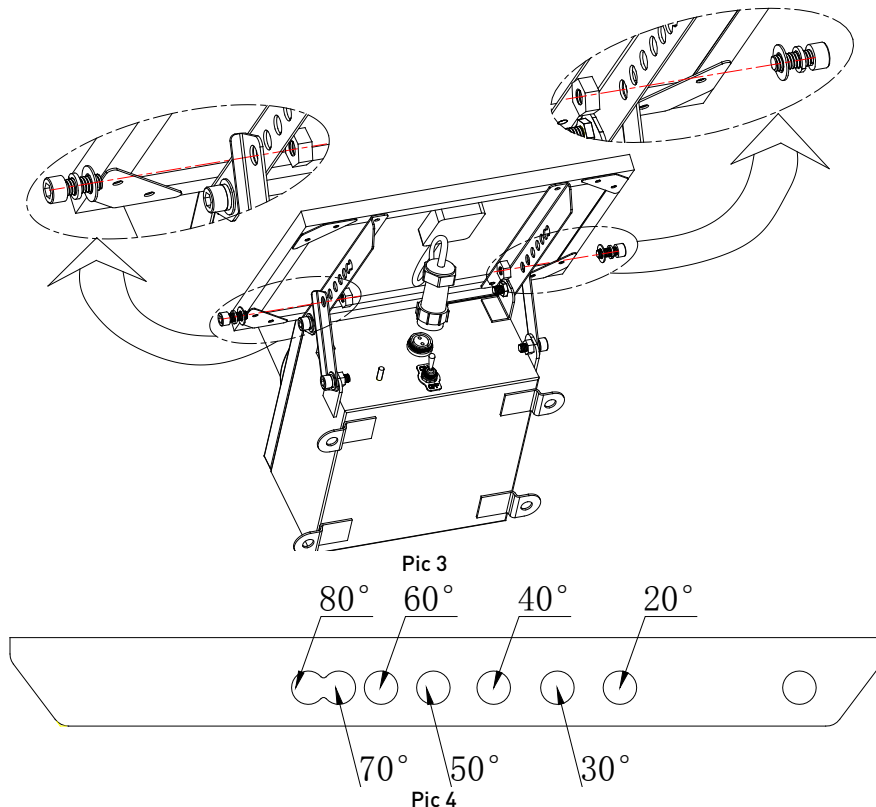

c. Firstly, open the cover of the case kit socket, then put solar panel on the plug into the socket of the component, fix the plug, Please see pic 5;

Noted: Plug and socket have anchor point, need match to fit in; Plug nut must tighten to the socket, to prevent the bad line contact.

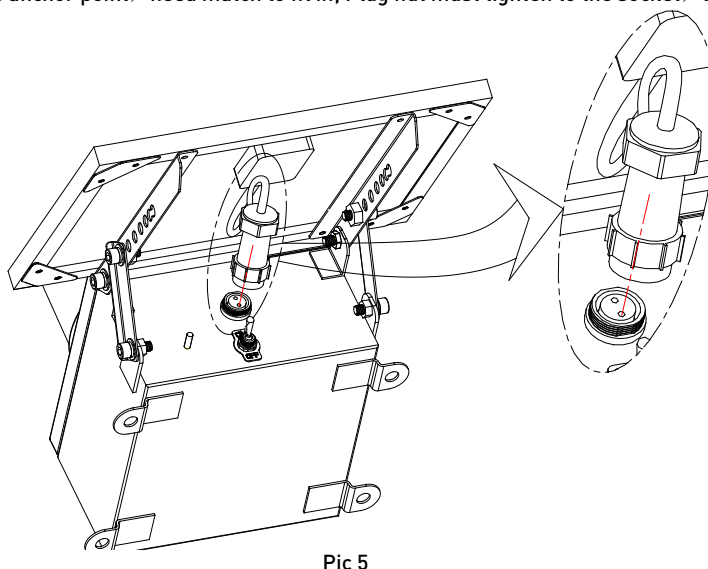

d. Use M8 fixed all screws.

Noted: All screws, nuts no loose.

• Check the whole lamp:

a. According to the require of the 2nd step after assemble the solar panel, open the box switch(Dial ON), Observe the light flash, if flash, solar battery to plug and socket not fix(in daytime); on the other hand, for next step;

LT864

Medium Intensity Solar Aviation Obstruction Light



b.Covered in solar panel with an object, re-checking light flash, flashing means finished product assembly, can be install on tower, closed button switch(Dial OFF);

Noted: Solar panel need 100% cover, ensure no light irradiation on it (to be night) .

c.After the whole product install to the tower, turn on switch(dial ON), light start working.

Precautions

- The part of material of products is PC(like lamp cover and lamp shell), so it cannot direct or indirect touch the organic solvent, such as industrial alcohol, banana oil, isotropic alcohol, carbon tetra chloride, cyclone and so on, otherwise, the product will be corrosion.
- Before installing the product,make sure the install position has enough space, the specific size should be not less than the installation size, the light specific please see the first left page as shown.
- More than 3 months stop working , need charge battery, 2 ways:
 - 1.Open the box, take out the battery, use external constant current power supply for battery charging, require 14V charging voltage, charge current 3A, large current charging for a period of time when the charging current is gradually reduce to close to 0 after stop.
 - 2.Put the light under the sunlight directly, and open the battery switch, charge the battery by sun energy. Turn off the battery switch after a full charge.
- Please do not open the control box by yourself when operating to avoid danger.
- This product is a sealed structure; should not be tampered with by anyone other than professional installer.
- Please use this product strictly on accordance with the instruction above.

Order number

Product Code	Light	GPS synchronization	Battery	Operating mode	Remarks
1000117-001	single	NO	12V/12AH/ lead-acid cell	20 times/min	
1000117-004	single	Yes	12V/12AH/ lead-acid cell	20 times/min	
1000117-006	Main +standby	NO	12V/12AH/ lead-acid cell	20 times/min	
1000117-007	Main +standby	Yes	12V/12AH/ gel battery	20 times/min	
1000117-008	single	No	12V/12AH/ gel battery	20 times/min	Stainless steel 316 box

Thank you for using our products, NANHUA as a signal transmission and high quality industrial lighting professional brand , Deeply trusted and loved by users in different industries around the world. Please be sure to use this product correctly on the basis of reading and understanding the instructions. Incorrect installation and use may cause fire, electric shock,etc. Due to product improvements, changes in specifications and patterns may be changed without notice, Please understand.
©NANHUA Electronics Co., Ltd. All rights reserved to . www.nanhua.com