

LQ006U

Aerial warning sphere



Products description and applicaiton

Designed to use for high-rise transimission lines, espacially for EHV(500,000KV)transmission cables,river-crossing transimission lines to provide the warning marks.



Features

- o Colored weatherproof glaze
- o Corrosion resistance, ambient temperature: -40 °C ~ +90 °C , Can be used under very hostile conditions.
- o Normal screw mounting, distribute bushings.
- o FRG material property: Tensile strength \geq 128MPa; flexural strength \geq 230MPa; Barcol hardness \geq 44.

General Specifications

Standard	Conforms to ICAO Item 14
color	white/red/orange/orange and white/orange and red
Cable clamp	Cable diameter \varnothing 19/ \varnothing 30 including bushing or designated
size	600X2.1mm/800X2.1mm/1300X2.1mm
Material	sphere: FRG clamp: die-casting alloy
Ambient temperature	-40°C ~ +55°C
weight	<15Kg

Mounting dimensions

LQ006U

Aerial warning sphere



Unit:mm

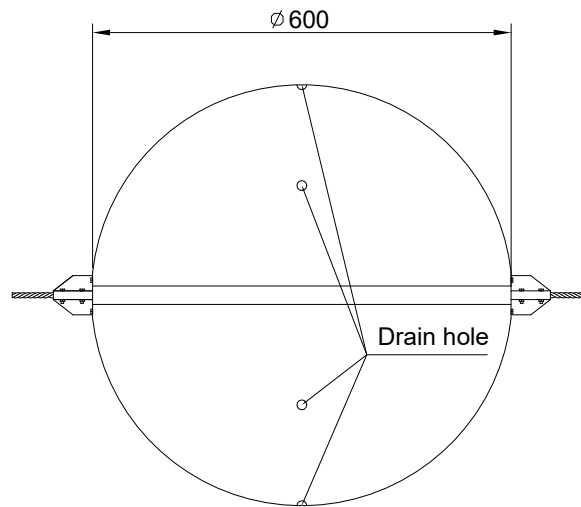

Installation method of use

- Mounted on the wirerope of lightning protection ground of the overhead tower. The distance between each two spheres is the following:
 - a, if the diameter of sphere is 600mm, the distance is no more than 30m
 - b, if the diameter of sphere is 800mm, the distance is no more than 35m
 - c, if the diameter of sphere is 1300mm, the distance is no more than 40m, Equal Interval setting.
- It has red, white, orange. The setting should be interphase.
- Involved multiterm lines, cables situation, the height of the spheres should not be lower than the height of the highest marked overhead line.

Note

- Line diameter can not exceed the range regulated by the clamp, designated for the special situation.
- Choose two different colors spheres at the meanwhile, interphase setting.

How to Order

Order No.	Model No.	Size	Color	Wire Size Range
1000096-001	LQ006U	ø600X2.1mm	Orange and white	6.5~9.5mm (Clamp:14.4mm)
1000096-002	LQ006U	ø600X2.1mm	White	14.6~18.1mm (Clamp:23mm)
1000096-003	LQ006U	ø600X2.1mm	Red	14.6~18.1mm (Clamp:23mm)
1000096-004	LQ006U	ø600X2.1mm	Red and white	8.1~11.1mm (Clamp:16mm)
1000096-005	LQ006U	ø600X2.1mm	Orange and white	15.6~19.1mm (Clamp:24mm)
1000096-006	LQ006U	ø600X2.1mm	White	15.6~19.1mm (Clamp:24mm)
1000096-007	LQ006U	ø600X2.1mm	Orange	15.6~19.1mm (Clamp:24mm)