

■ EBL-RE-LED

■ LED Elevated Runway Edge Light



Compliance with Standards

CAAC: AC-137-CA-2015-01&03
 SAC: GB/T 7256
 ICAO: Annex 14, Volume I
 IEC: TS 61827
 FAA: AC 150/5345-46 & EB NO.67
 NATO: STANAG 3316

Application/Use

Runway edge light for CAT I, II, III

Features

- LED rated 70,000 hours, effective energy saving, maintenance-free, which brings enormous economic benefits to customer
- Consistent dimming curve with halogen lamp fixture, complying with FAA standards
- Strict LED color management to ensure premium color consistency
- Proprietary driving circuit and thermal management solution, which greatly improves the reliability and service life of light fixture
- Power factor above 0.9, which minimizes the power network interference
- Optional function of single lamp failure detection, which enables the light to be open as halogen lamp once LED fails
- Compact structure and attractive appearance, with small windward area and strong wind resistance capability
- The main body is made of aluminum alloy with anti-corrosion surface treatment, all fasteners are made of stainless steel, suitable for various harsh environment applications
- High-precision parts and components machining to ensure all dimensional quality and accuracy
- Forged frangible device with precise machining, complying with FAA standards, ensuring good stability and reliability
- IP67-grade ingress protection of the fixture, keep interior from dust
- Unique optical design to meet ICAO requirement of circling guidance

Ordering Information

EBL-RE-LED-XX-X

Type _____
 EBL-RE=Elevated Runway Edge Light

Light Source _____
 LED=LED lamp

Beam Color _____

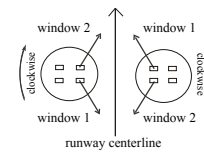

YC=Window 1: yellow window 2: white
 CY=Window 1: white window 2: yellow
 CC=Both windows: white
 CR=Window 1: white window 2: red
 RC=Window 1: red window 2: white

Optional Function _____
 M=Single lamp fault detection function

* Please provide detailed installation info while ordering, spare parts and accessories should be separately ordered with specific order no.

Installation

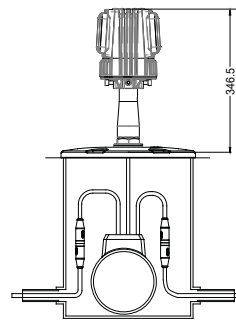

Fig 1. On 12" deep base

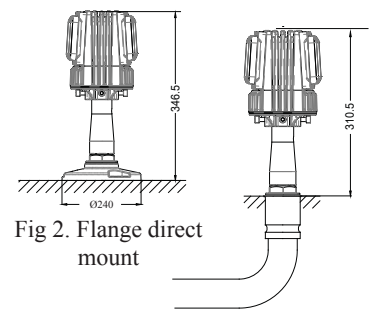

Fig 2. Flange direct mount

Fig 3. Embedded pipe mount

* Please find detailed information in installation manual

Structure

1. front cover
2. optical cover gasket
3. optical cover
4. LED lamp assy
5. light body
6. light body gasket
7. transformer
8. driver assy
9. light body holder
10. waterproof gland
11. frangible pole
12. plug

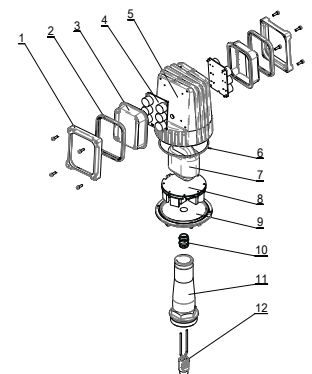

■ EBL-RE-LED

■ LED Elevated Runway Edge Light

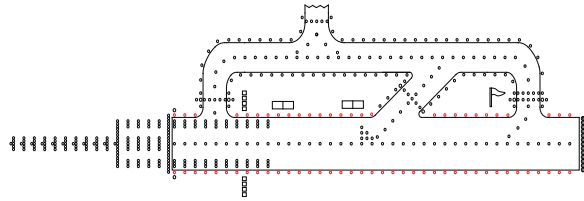

Specifications

Light source: 6 Clear/Red/Yellow LED particles per side
 Power: 36 VA
 Power factor: ≥ 0.9
 IP grade: IP67

Photometric Data

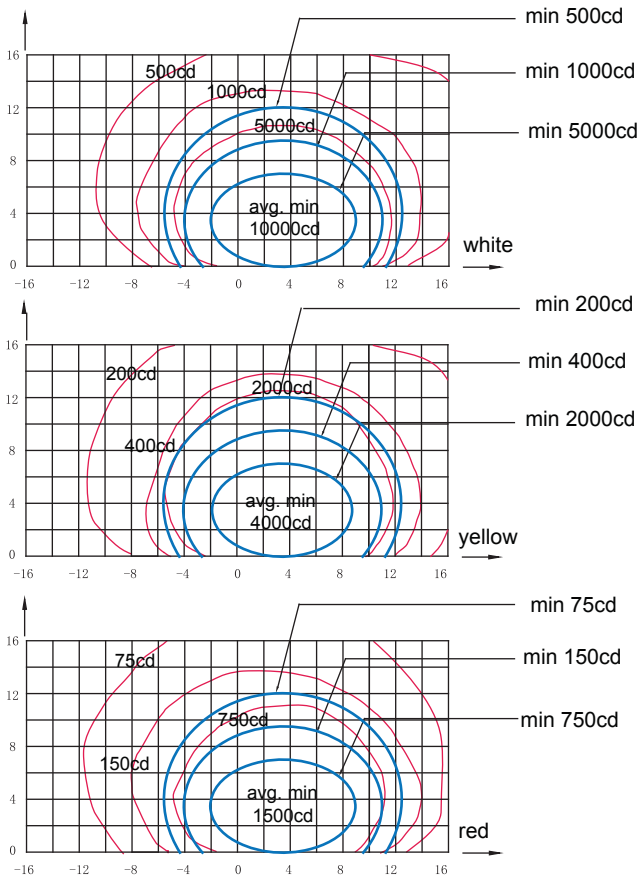

EBL-RE-LED, ICAO Figure A2-9, FAA L-862

Application		Main Beam		Color	Required min avg. cd	Actual avg. cd
		H	V			
EBL-RE-LED	ICAO Figure A2-9/ FAA L-862	$\pm 5.5^\circ$ (Toe-in 3.5°)	0°—7°	White	10000	11982
				Yellow	4000/5000	9273
				Red	1500/2000	2523
	ICAO Figure A2-10	$\pm 6.5^\circ$ (Toe-in 4.5°)	0°—7°	White	10000	10392
				Yellow	4000	8928
				Red	1500	2411

Packing Data

4 lights Size: 220×220×265 mm³
 Unit net weight: 4.2 kg Gross weight: 17.9 kg

Spare Parts

Struc No.	Part Name	Order No.	Description
1	front cover	24135	optical cover bracket ring
2	optical cover gasket	41149	front glass seal gasket LED
3	optical cover	3110A	for LED runway edge light - front glass
4	LED lamp assy	79243-C	LED light source 85×63.5 white
		79243-R	LED light source 85×63.5 red
		79243-Y	LED light source 85×63.5 yellow
5	light body	241K1	for bidirectional LED lights
6	light body gasket	41161	"O" ring seal 106×3
7	transformer	BR45-11346	r-core transformer 45W
8	driver assy	979143	PCB-Approach light-12X(Assy)
9	light body holder	241J1	light body holder
10	waterproof gland	48404	waterproof gland MG18×1.5
11	frangible pole	24211	frangible pole
12	plug	HT 70603	secondary cable connector - Style 6 HT

Accessories

Description	Order No.
flange 240mm	276A1
flange 304mm (FAA standard)	27683
hex wrench for frangible pole of elevated lights	54101
calibrator assy	946478
secondary cable receptacle - style 7	70703
45-watt isolation transformer	ITF-045-066
isolation transformer housing	TJB-12