



Compliance with Standards

CAAC: AC-137-CA-2015-09
 SAC: GB/T 7256
 ICAO: Volume 14, Volume I
 IEC: TS 61827
 FAA: AC 150/5345-51B
 FAA: E-2628b
 FAA-P-2965 PAR-56
 NATO: STANAG 3316

Application/Use

Approach System, Flashing Light,
 Runway Threshold Indicator

Dimensions

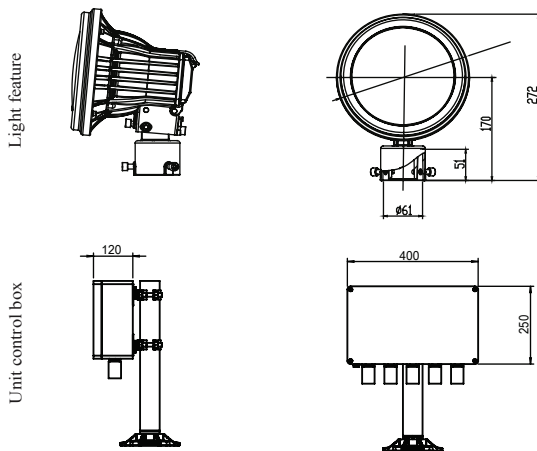

Installation

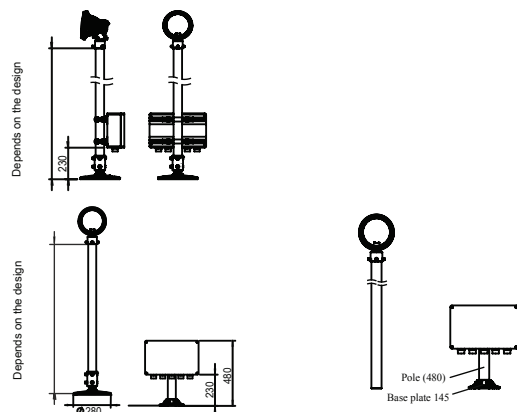

Ordering Information

SFLS-XP-XX/XX-XXX-XX

SFLS _____

SFLS = Sequenced flashing
 lighting system

Power supply _____

3P = Three-phase power supply
 1P = Single-phase power supply

Number of Heads _____

00/01 = 0 elevated light/1 insert light
 01/01 = 1 elevated light/1 insert light
 01/09 = 1 elevated light/9 insert light
 19/02 = 19 elevated light/2 insert light

 30/00 = 30 elevated light/0 insert light

Communication Mode _____

CAN = CAN communication
 PLC = Carrier communication

Flashing Frequency _____

01 = 1 HZ
 02 = 2 HZ

* Please provide detailed installation info while ordering,
 parts and accessories should be ordered separately specific
 with order no.

Photometric Data

Beam angle: horizontal $\pm 15^\circ$, verticle $\pm 5^\circ$
 Flash frequency: once or twice pro second
 Light intensity: I class 2% (150~450 cd)
 II class 10% (800~2,000 cd)
 III class 100% (8,000~20,000 cd)
 Reflector ratio: > 95%
 Elevation angle: 0 to 15 degrees verticle

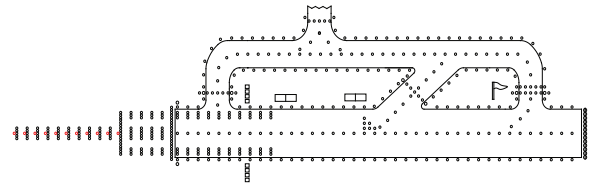

Features

- Light distribution and chromaticity conforming to the specifications contained in FAA-E-2628 and CAAC of China
- Low-Voltage flashtubes ensures low operation voltage of the whole system
- Self-alignment optical component without need of recalibration when replacing bulb as well as optical components
- Elevated type and in-pavement type
- The main body is made of aluminum alloy with anti-corrosion surface, all fasteners are made of stainless steel, suitable for harsh environment application
- The prism of in-pavement type is made of tempered glass material, which can withstand wind and sand erosion
- Upper cover of in-pavement type featured by equal-strength design and forging craft, which has premium mechanical and carrying capacity, and shock resistance ability
- Elevated type achieves IP65-grade protected from total dust ingress, and in-pavement type, IP68-grade, that can withstand inner pressure of up to 138kpa or water pressure generated from aircrafts' impact on the optical window
- High-precision machining to ensure all dimensional quality and precision
- Each lighting fixture comes with unit control cabinet that has concise cable layout, which is easier for maintenance and servicing
- Both main control cabinet and unit control cabinet have self-contained CPUs, which runs independently and operate in synergy via BUS communication
- Any component failures will not result in breakdown of system, ensuring reliable system operation
- The system has detection functions for bulb lifetime, flash skips(misfiring), on-line faults, etc.
- Main control cabinet equipped with LCD display, which accumulates statistical records of system operation
- Monitoring system achieves remote control and uploads of operation status
- Circuits, power and communication cables are equipped with lightning protection, conforming to the requirements contained in FAA
- The elevated fixture can be connected to both one or two-inch frangible tube, which ensures convenient and secure installation
- Forged frangible couplings with precision machining, which complies with FAA requirements and ensure reliable and stable performance

Accessories

No.	Description	Order number
1	Main Control Box Panel	66110
2	Flashing Light	66230
3	Unit Control Box	66220
4	Flashing Lamp	L40JS
5	Unit Control Box circuit board	79108
6	Light circuit board	79107
7	Reflector	31147
8	Front glass	31146
9	Sealing ring	41119
10	Rear cover seal	41111

Packing Data

- 1 Light unit, Weight: 7.2 kg, Dimensions: 376×296×446 mm³
- 1 Base plate, Weight: 3.9 kg
- 1 Frangible coupling, Weight 0.6 kg